

BIESSE ROVER A FT

NC processing centre

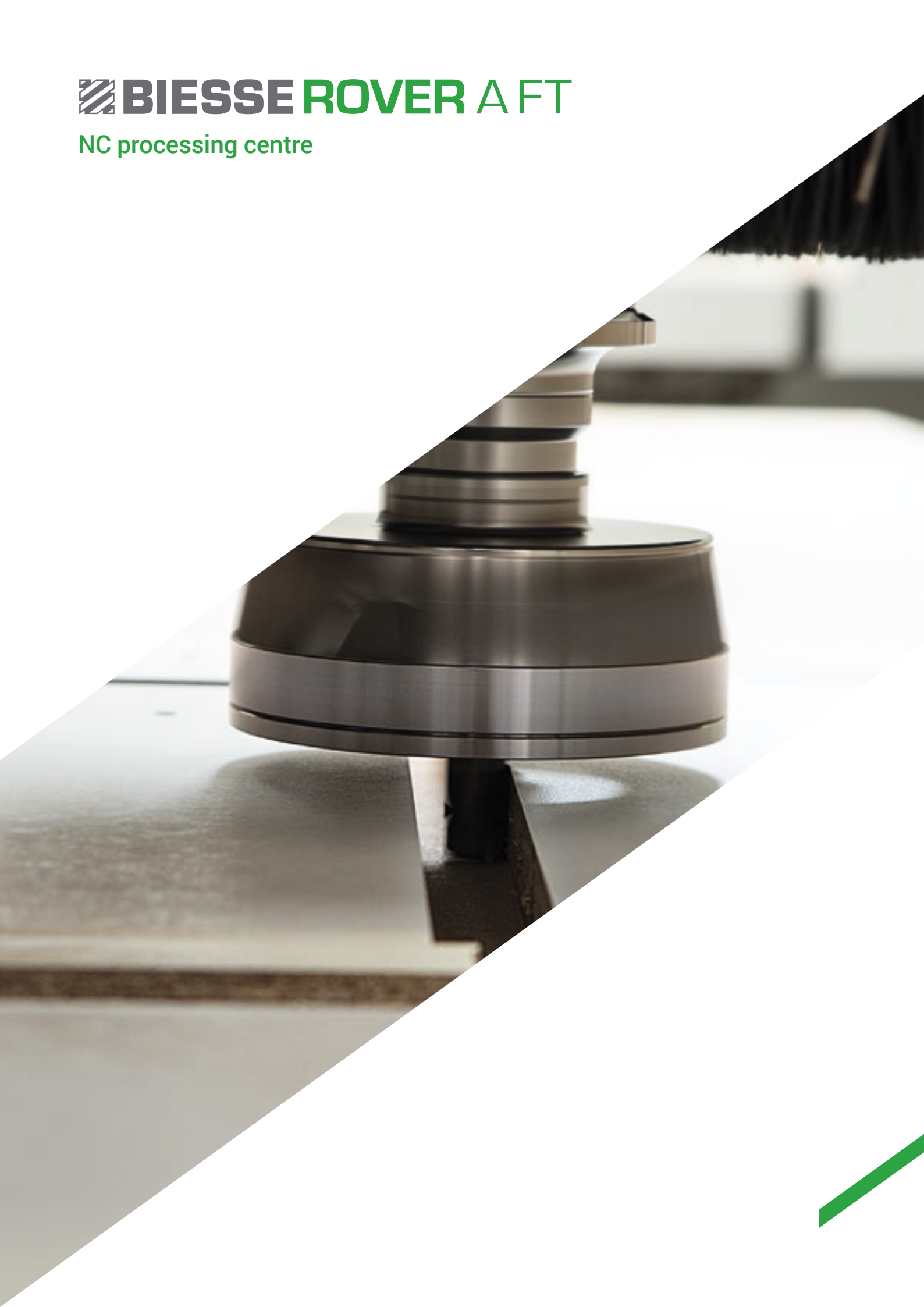

When competitiveness
means increasing
productivity

Rover

Made **in** Biesse

The market demands

a change in manufacturing processes, enabling companies to accept the **largest possible number of orders**. This is coupled with the need to maintain high quality standards whilst offering product customisation **with quick and defined delivery times**.

Biesse reacts

with high-tech, innovative solutions for nesting operations. **Rover A FT** is the new entry-level processing centre for nesting machining operations aimed at craftspeople and small enterprises that offers top-of-the-range technology at a competitive price point.

- ✓ **Long term reliability and precision.**
- ✓ **Biesse's experience at the service of craftspeople.**
- ✓ **Compact footprint and superior ergonomic performance.**
- ✓ **Ability to handle both large and small panels of varying thickness.**

A single processing
centre for all types
of machining
operations

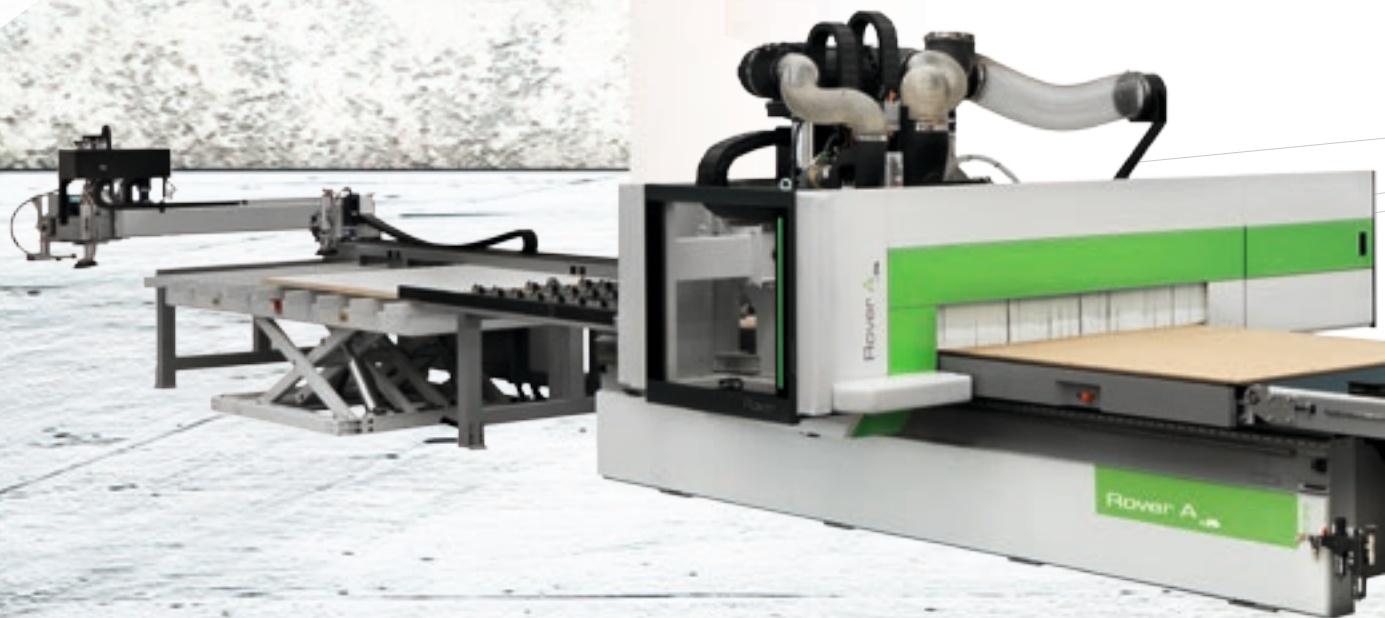

ROVER A FT
NC processing centre



A single processing centre for many types of machining operations

Rover A FT enables users to carry out different types of machining operations and achieve a finished, fully-machined product with a single machine.





High reliability and precision over time

Rover A FT has a robust and well-balanced structure, designed to handle demanding machining requirements without compromising product quality.



The heavy **monolithic base** guarantees solidity and absence of vibration, for consistent product quality over time.

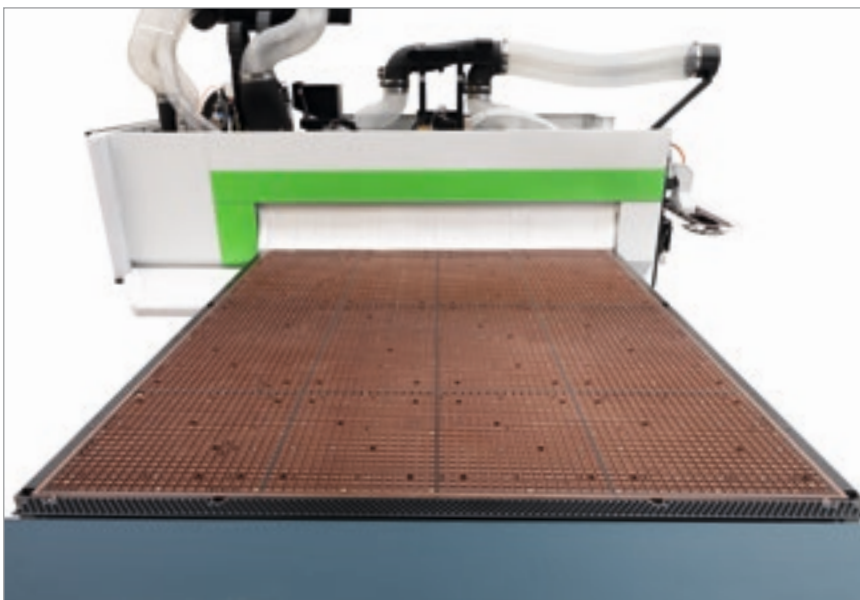

The **Gantry structure** with dual engine is designed to increase precision and reliability standards for the execution of machining operations.



Automated lubrication is an option that ensures the continuous lubrication of the machine's main moving parts without the need for operator intervention.



Cutting-edge solutions for the **mechanical drive** ensure high precision and reliability over time.



Higher motor power **increases acceleration up to 4 m/s² and speed up to 100 m/min.**

Biesse's experience at the service of craftspeople

A specific Research & Development team creates pioneering solutions to meet the market requirements and offer cutting edge technology that's reliable and guarantees first class results. Biesse uses the same high-tech components for all machines in its product range.



The electrospindle, boring head and aggregates are designed and manufactured for Biesse by HSD, the global leader in this sector.



C Axis Torque: more precise, quicker, greater rigidity.

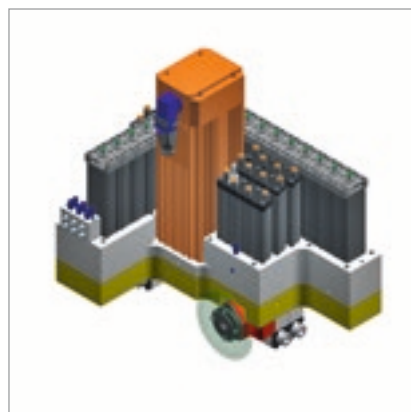

New BH18 / 25L boring head for the highest drilling capacity and productivity in its class.

A complete range of aggregates



Up to 32 tools and aggregates available in the tool changer, which are loaded automatically when switching from one machining operation to the next.

Openable rear trim to reduce set-up times.

Productive economy

Biesse's processing centres for nesting operations allow to achieve a finished produced machined on a single, compact machine at a competitive price. The robust and well-balanced structure of the machine is ideally suited for withstanding greater processing stresses without compromising the quality of the piece and for ensuring the best finish on different types of materials.

Various loading and unloading solutions customised based on production requirements enable a significant cost reduction.

NESTING SOLUTIONS

Productivity and efficiency are increased, while maintaining high quality standards and fast delivery times.

A perfect combination of Biesse optimisation and Italian genius.



Compact footprint and superior ergonomic performance

Rover A FT in the stand-alone version is the most compact solution on the market. It enables the operator to access the machines' three sides, guaranteeing maximum ergonomic comfort and safety.



The rack magazine with 6/8 positions supplies a simple and functional solution with minimum footprint.

Increasing manufacturing capacity



The machine can be configured with **tandem loading** in order to alternately process panels. This allows for loading or unloading to be carried out during machining operations.

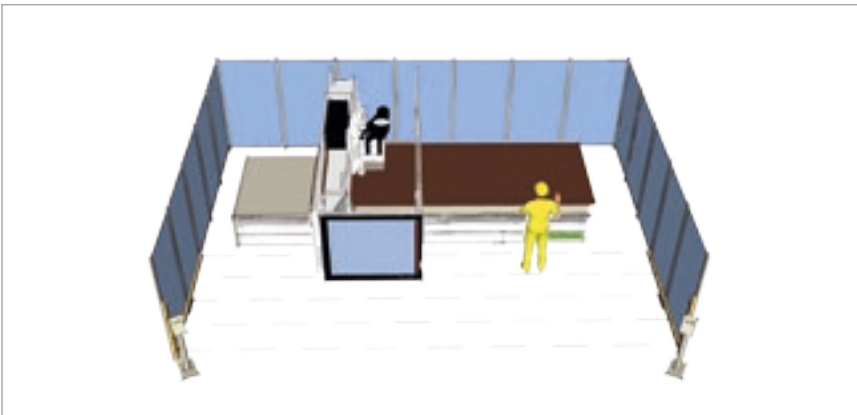

Can be fully integrated into a working cell

Rover B FT can be customised to the work flow depending on customer requirements.

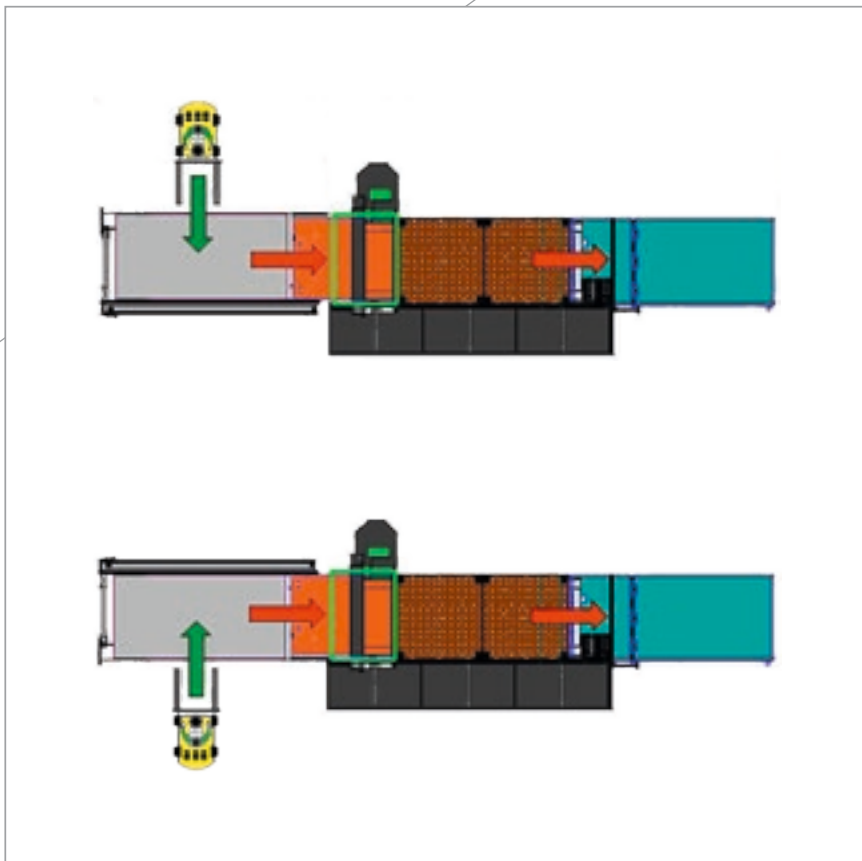

Loading/unloading operations are carried out simultaneously, allowing the operator to remove completed components from the unloading station in the utmost safety whilst the machine is already processing the next panel.



Panel identification and traceability within the production flow thanks to **automatic or manual labelling**.

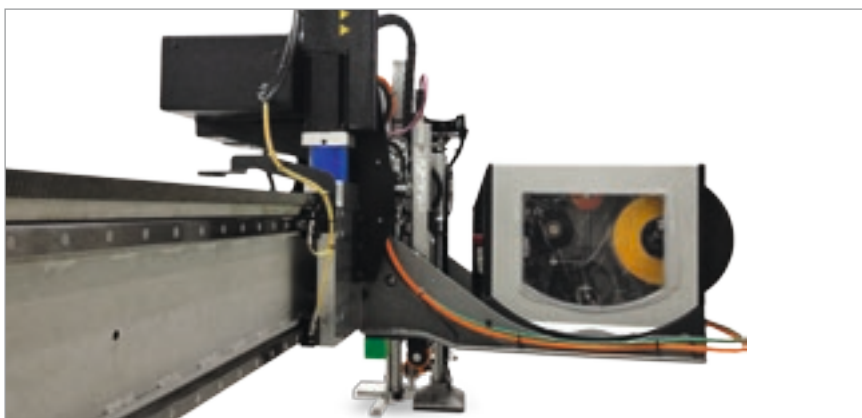

The new sweeper arm does not entail any limits to the passage of the piece in z.

Panel loading system with **scissor lift** and automatic panel alignment. The system's ease of use ensures long term reliability.

The **loading system** enables the handling of both porous and non-porous materials of thicknesses greater than 9mm, whilst also offering automatic labelling.

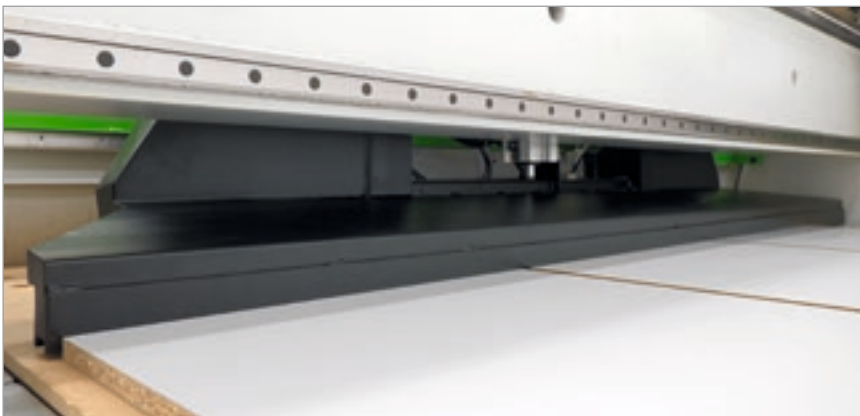

Machine efficiency is dramatically increased due to the **unloading belt**, which enables the removal of completed components outside the machine's work area.

Competitive customisation

Biesse Systems is a team of highly trained engineers for large scale production processes. Biesse Systems offers integrated cells and systems that are capable of maximising customer competitiveness by combining mass production techniques with a high degree of customisation to meet customers' exact requirements.

PRODUCTION LINES

Made-to-measure turnkey factories, plus the integration of Biesse Group solutions with complementary software and machinery, with over 300 systems installed worldwide. A perfect combination of Biesse Group's experience and Italian genius.



Handling both small and large panels of varying thickness



Advanced **work table** technology to machine panels of different types and sizes with the utmost reliability.

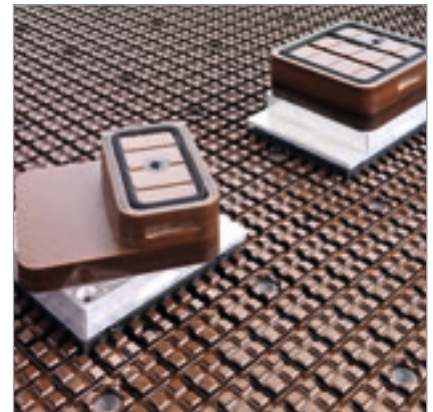
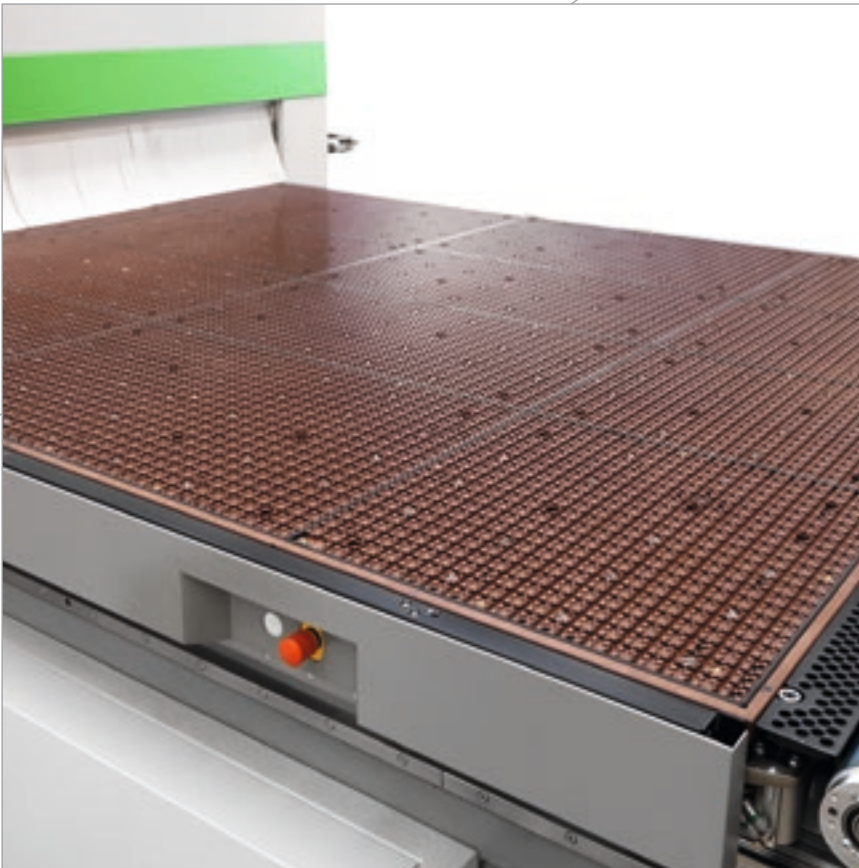

Vacuum modules freely positionable on the FT work table without the need for dedicated connections.

Maximum panel security thanks to an advanced distributed vacuum system within the work table.

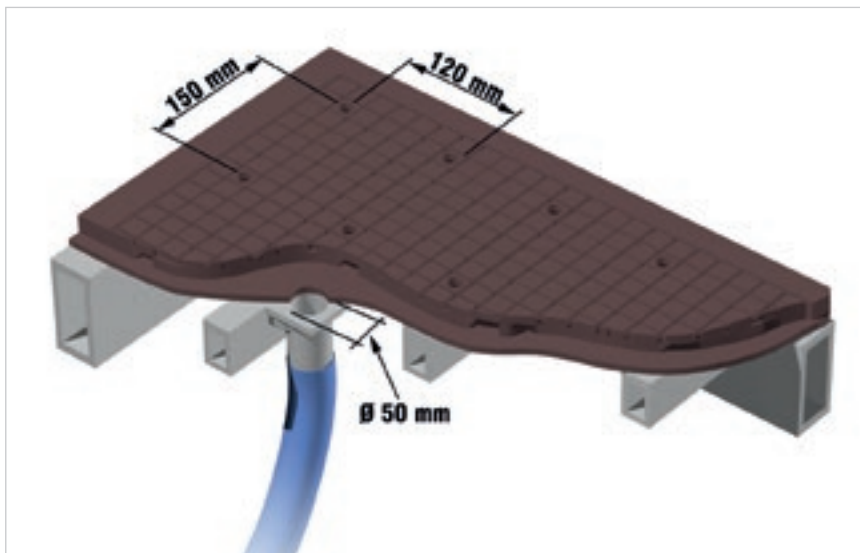

Multi-zone technology able to concentrate the vacuum in smaller areas of the work table where required, in order to hold smaller components and reduce vacuum loss.



Optimal cleaning of machined components and work area

Various automatic machine and component cleaning options are available which saves operator time.



Adjustable **suction hood** with 6 settings.

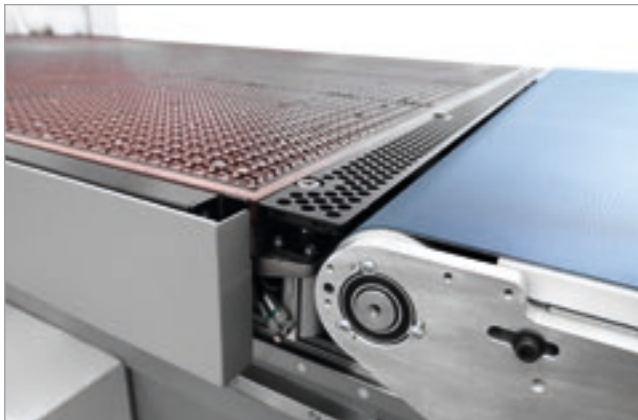

Vacuum aspiration from below, between machine and unloading belt.



Additional aspiration kit for unloading belt consisting of 2 suction hoods, on the top and one at end of the belt.

Maximum operator safety

Biesse machines are designed to enable operators to work in complete safety.



Working unit total protection. Maximum visibility of machining operation. LED bar with 5 colours showing machine status in real time.



Perimeter guards with access door and safety device to prevent accidental contact with the machine.



Overlaid layers of side curtain guards to protect the working unit, which are flexible to enable the machine to work at maximum speed in total safety.

Long term safety and reliability thanks to the new **bumpers combined with photocells** with no footprint or mechanical wear.



High-tech becomes accessible and intuitive



bSolid is a 3D cad cam software program that supports the performance of any machining operation thanks to vertical modules designed for specific manufacturing processes.

- ✓ **Planning in just a few clicks, with endless possibilities.**
- ✓ **Simulating machining operations to visualise the component prior to manufacturing as well as providing guidance for the planning phase.**
- ✓ **Virtual prototyping of the component to avoid collisions and ensure optimal machine efficiency.**

Watch the **bSolid** ad at: youtube.com/biessegroup



bSolid



Reduced time and waste



bNest is the bSuite plugin specifically for nesting operations. It allows you to organise your nesting projects in a simple way, reducing the material waste and machining times.

- ✓ Reduced production costs.
- ✓ Simplified work for the operator.
- ✓ Integration with company software.



bNest

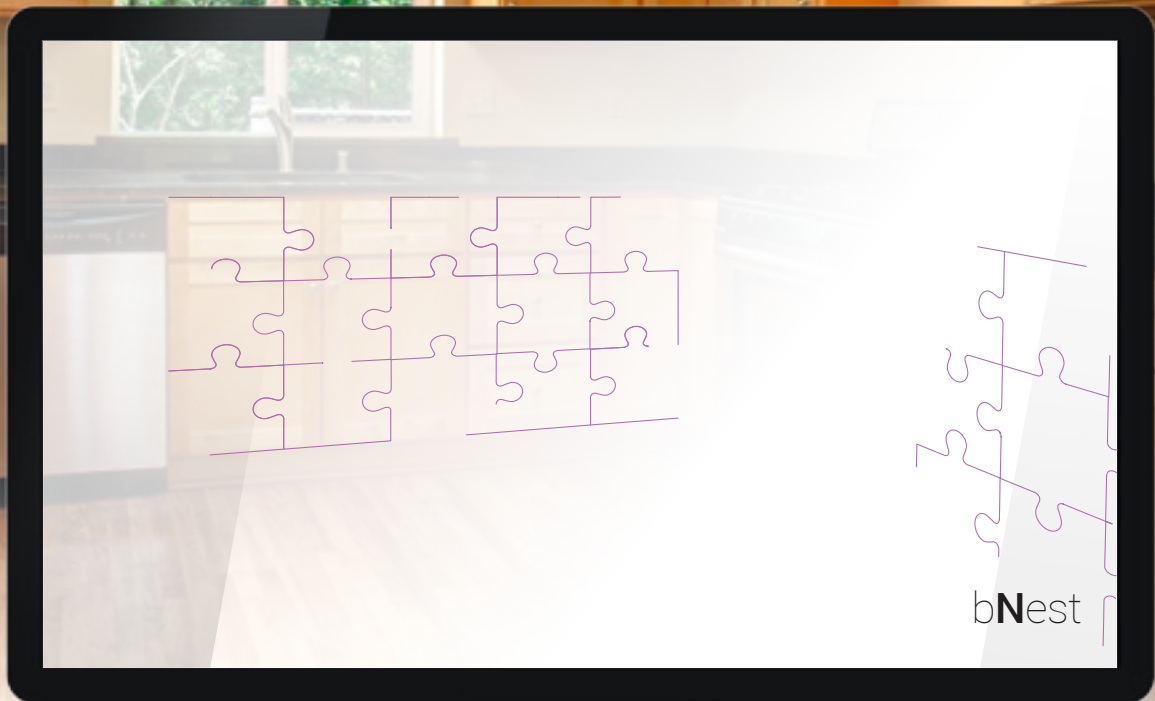

Ideas take form and shape



bCabinet is the bSuite plugin for furniture design. It allows users to develop designs for a given space, and to quickly identify the individual elements that make it up.

- ✓ With the new plugin, it is easy to draw both individual items of furniture and complete furnishings for a range of spaces.
- ✓ Offering optimal integration with bSuite, users can move from design to manufacturing in just a few clicks.
- ✓ Total control and maximise the optimisation of the furniture design and creation process, to achieve the highest levels of efficiency.

bCabinet

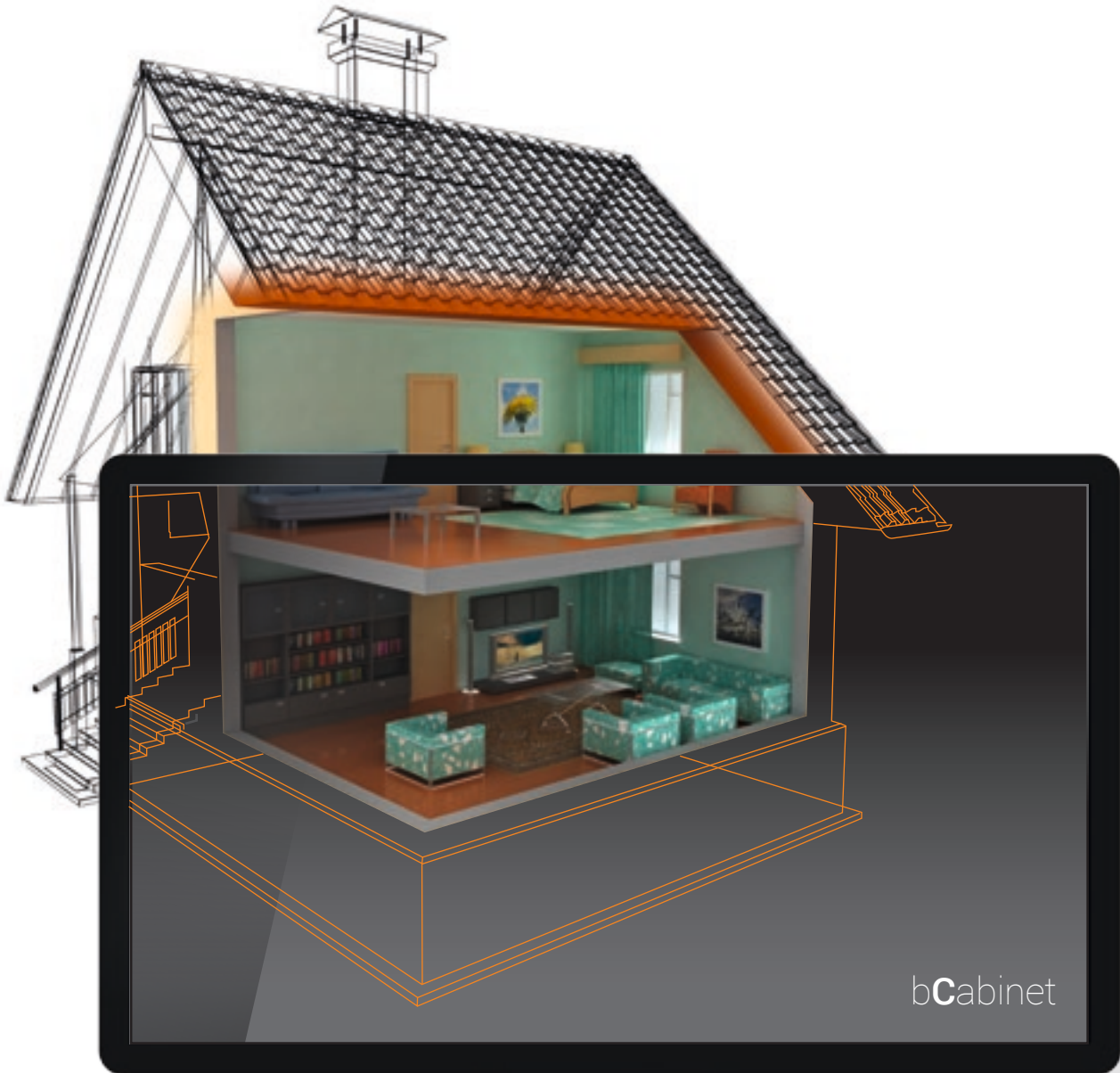

Configuration

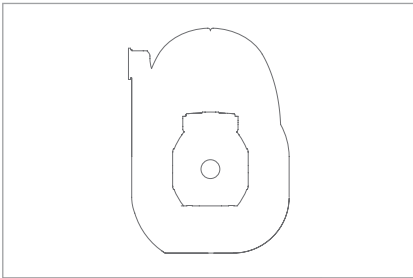

Milling unit from 13.2 to 19.2 kW.

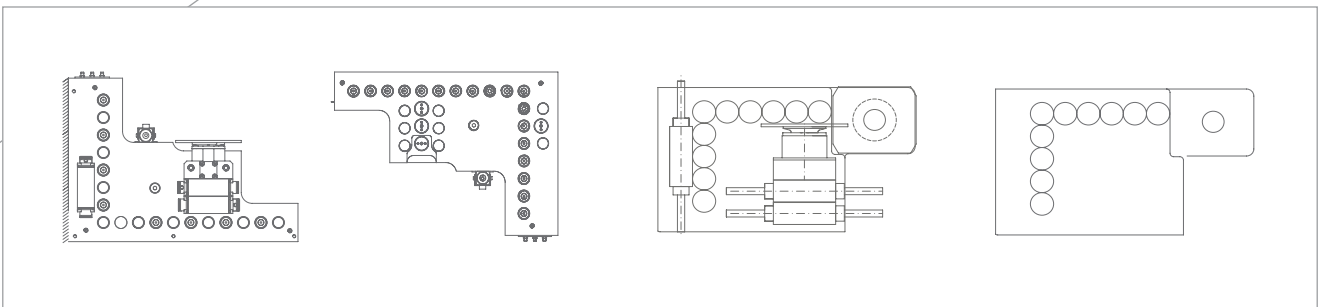

Boring heads available from 10 to 25 spindles: BH25 L - BH18 - BH17 - BH10.



Technical specifications

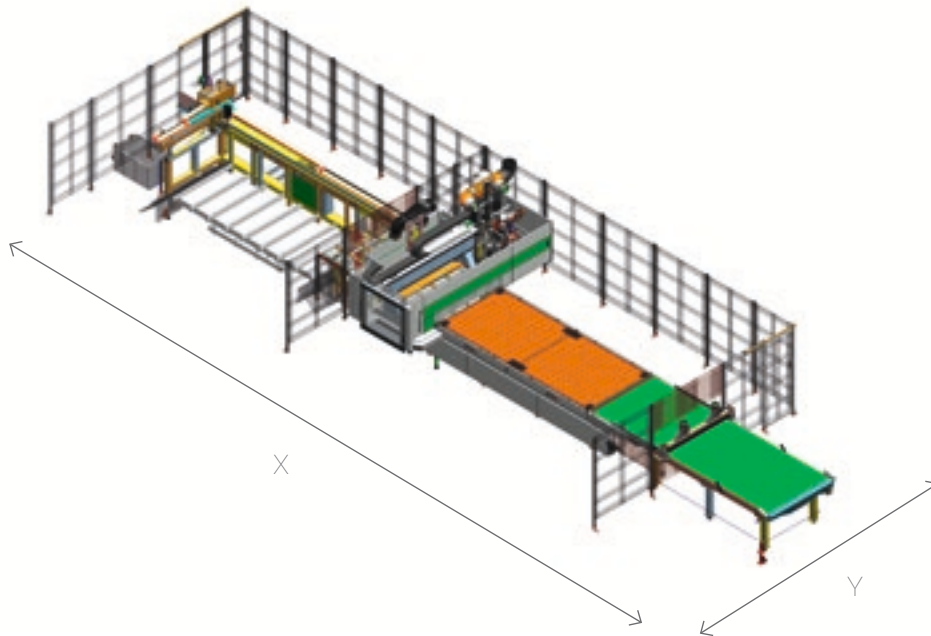

Working fields

	X	Y	Pendular
	mm	mm	mm
Rover A FT 1224	2465	1260	-
Rover A FT 1531	3100	1560	-
Rover A FT 1536	3765	1560	1340
Rover A FT 1836	3765	1875	1340
Rover A FT 2231	3100	2205	805
Rover A FT 2243	4300	2205	1405

X/Y/Z axis speed	85/60/20 m/min
Vector speed	104 m/min

The technical specifications and drawings are non-binding. Some photos may show machines equipped with optional features. Biesse Spa reserves the right to carry out modifications without prior notice.

A weighted sound pressure level (LpA) during machining for operator workstation on vane-pump machine Lpa=79dB(A) Lwa=96dB(A) A-weighted sound-pressure level (LpA) for operator workstation and sound power level (LwA) during machining on cam-pump machine Lwa=83dB(A) Lwa=100dB(A) K measurement uncertainty dB(A) 4

The measurement was carried out in compliance with UNI EN 848-3:2007, UNI EN ISO 3746: 2009 (sound power) and UNI EN ISO 11202: 2009 (sound pressure levels at workstation) during panel machining. The noise levels shown are emission levels and do not necessarily correspond to safe operation levels. Despite the fact that there is a relationship between emission and exposure levels, this may not be used in a reliable manner to establish whether further measures need to be taken. The factors determining the exposure level for the workforce include length of exposure, work environment characteristics, other sources of dust and noise, etc. i.e. the number of other adjoining machines and processes. At any rate, the above information will enable the operator to better evaluate dangers and risks.

Service & Parts

Direct, seamless co-ordination of service requests between Service and Parts.
Support for Key Customers by dedicated Biesse personnel, either in-house and/or at the customer's site.

Biesse Service

- ✓ Machine and system installation and commissioning.
- ✓ Training centre dedicated to Biesse Field engineers, subsidiary and dealer personnel; client training directly at client's site.
- ✓ Overhaul, upgrade, repair and maintenance.
- ✓ Remote troubleshooting and diagnostics.
- ✓ Software upgrade.

500 / Biesse Field engineers in Italy and worldwide.

50 / Biesse engineers manning a Teleservice Centre.

550 / Certified Dealer engineers.

120 / Training courses in a variety of languages every year.

The Biesse Group promotes, nurtures and develops close and constructive relationships with customers in order to better understand their needs and improve its products and after-sales service through two dedicated areas: Biesse Service and Biesse Parts.

With its global network and highly specialised team, it offers technical service and machine/component spares anywhere in the world on-site and 24/7 on-line.



Biesse Parts

- ✓ Original Biesse spares and spare kits customised for different machine models.
- ✓ Spare part identification support.
- ✓ Offices of DHL, UPS and GLS logistics partners located within the Biesse spare part warehouse, with multiple daily pick-ups.
- ✓ Order fulfilment time optimised thanks to a global distribution network with de-localised, automated warehouses.

87% / of downtime machine orders fulfilled within 24 hours.

95% / of orders delivered in full on time.

100 / spare part staff in Italy and worldwide.

500 / orders processed every day.

Made **With** Biesse

Maton and Biesse make music together.

With more than 1200 models of guitars made for thousands of professional musicians, Maton Guitars confirms its worldwide presence, becoming a truly great Australian success story. "The best guitar is the one that the market demands," states Patrick Evans, Head of Product Development at Maton. The evolution in production techniques and research into the most efficient software continues, prompting Maton to hunt for new solutions that can better respond to emerging needs. In 2008, after considering the pros and cons of a range of manufacturers, Maton chose Biesse. Maton's production needs incorporate technological requirements and artisan skills; the right balance of these two allows them to achieve the highest levels of quality and performance. A great guitar is both a work of art and a fine musical instrument. To obtain these results, the right tools are crucial - both for heavy machining operations and delicate processes, to create 3D shapes and work with minimal tolerances. Biesse has provided Maton with a range of advanced solutions for machining processes, not only adding quality to the products, but also providing the skilled craftsmen with more time to devote to manual finishes, ensuring that every

product is unique. In 1995, the company installed their first CNC machine. They now have two nesting centres in tandem. The Rover C is the ideal machine for high-precision nesting operations, but also for creating complex shapes, such as the body of Maton's unique guitars. The machine's newly-designed cabin provides excellent visibility of all working units. Biesse is much more than a manufacturer of machinery for producing kitchens. Their impressive range of machines can process an astounding range of materials and products. "In creative hands," commented Patrick Evans, "Biesse becomes the instrument of a true craftsman. The key is to identify the right machine for the job. We found we can accomplish much more than we thought on a Biesse machine." Maton also uses the two Biesse machines to create new product prototypes; the most complex shapes, and almost every individual part which makes up a Maton guitar. Patrick confirms that Maton uses the Biesse CNC machine at high speeds even on the most complex parts, such as the magnificent fingerboard. "We need enough flexibility to be able to switch from one model to another very quickly, and Biesse allows us to do this very effectively." Biesse gives users the

creative freedom to produce virtually any concept, both quickly and efficiently. "With the Biesse's CNC machine," Patrick continues, "you can turn your ideas into reality much faster. Thanks to the flexibility provided by Biesse machines, we can produce two fingerboard prototypes in seven minutes! If we made them by hand, it would take a whole day. Using Biesse machines has allowed us to create eight new guitar models this year alone." Using Biesse machines has allowed Maton to devote more time to the quality of the finish, wasting less time on processing individual pieces. Each Maton guitar is hand-finished by a dedicated and qualified team of luthiers. Maton has demonstrated that it is possible to produce a guitar in Australia with a worldwide reputation for quality, using Australian timber and technologies. Maton knows exactly how to design and build a unique, one-of-a-kind product, a well-made guitar, and with Biesse as valued partner, the best guitars in the world are brought to life.

Taken from an interview with Patrick Evans, head of Product Development at Maton Guitars - Australia



<http://www.maton.com.au>



Biesse Group

In

1 industrial group, 4 divisions.
and 8 manufacturing sites.

How

€ 14 million p/a in R&D and 200 patents registered.

Where

33 branches and 300 agents/certified dealers.

With

customers in 120 countries, manufacturers of furniture, design items and door/window frames, producers of elements for the building, nautical and aerospace industries.

We

3000 employees worldwide.

Biesse Group is a global leader in the technology for processing wood, glass, stone, plastic and metal.

Founded in Pesaro in 1969, by Giancarlo Selci, the company has been listed on the Stock Exchange (STAR segment) since June 2001.

 **BIESSEGROUP**

 **BIESSE**

 **INTERMAC**

 **DIAMUT**

MECHATRONICS

