

SEL CO WNA 8

ANGULAR SIZING SYSTEMS

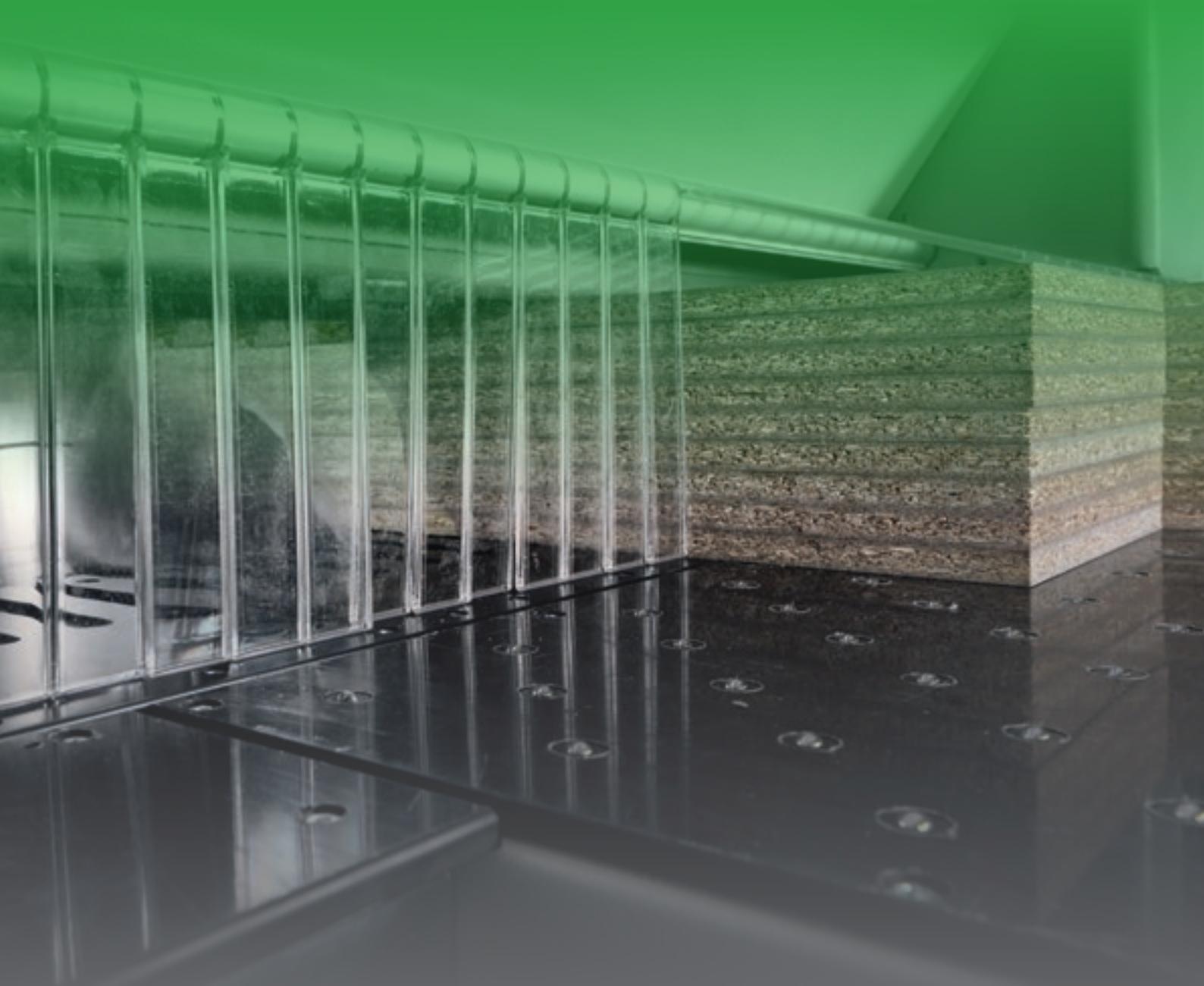

 **BIESSE**

TOTAL PRODUCTION EFFICIENCY

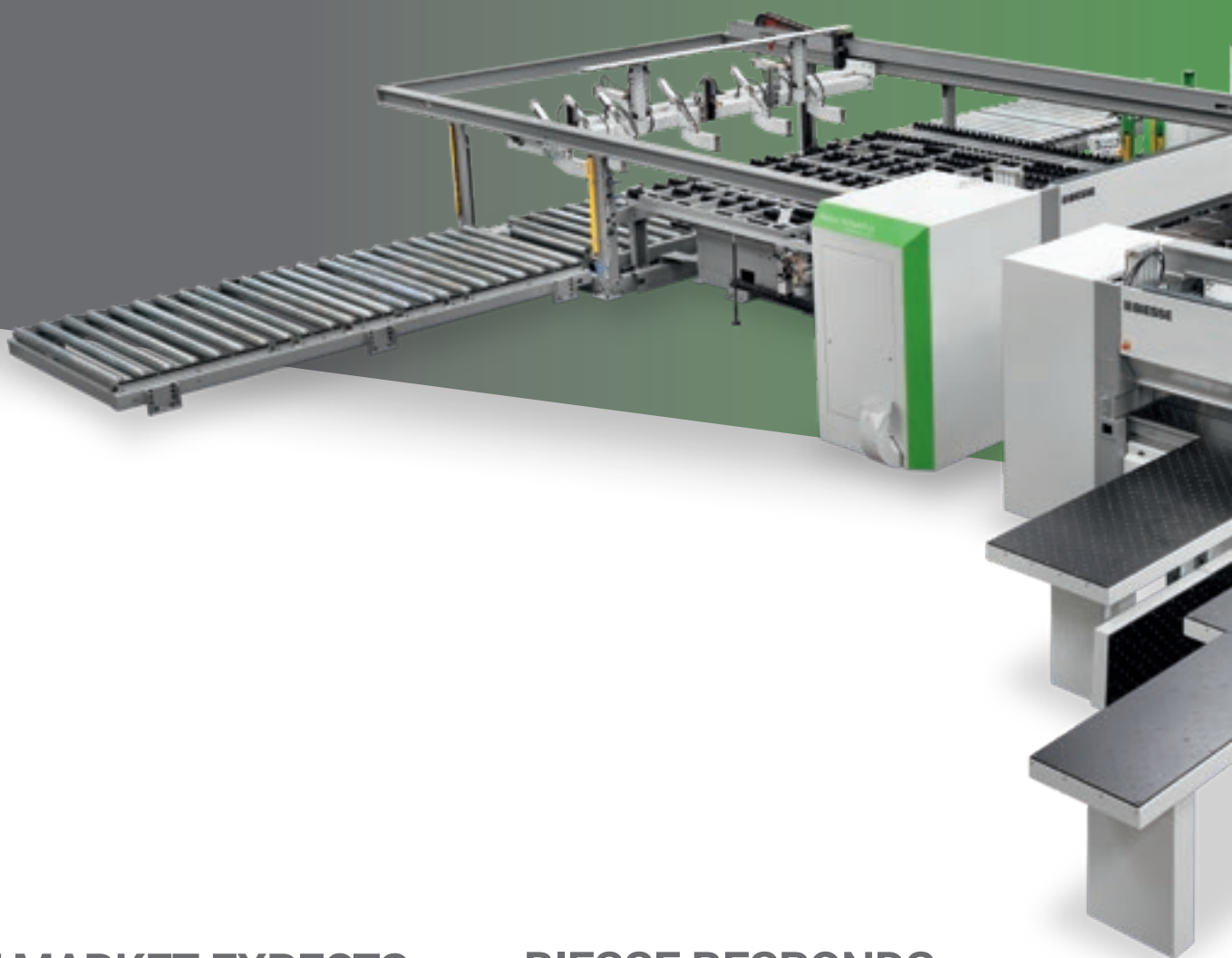

THE MARKET EXPECTS

a change in manufacturing processes, enabling companies to **accept the largest possible number of orders**. This is coupled with the need to maintain high quality standards while offering product customisation with **quick and defined delivery times**, as well as responding to the needs of the most highly automated enterprises.

BIESSE RESPONDS

with **technological solutions** that enhance and sustain technical expertise as well as a knowledge of the processes and materials.

SELCO WNA 8 is a range of sizing systems with two fully independent cutting lines and automatic loading, ideal for the needs of major businesses that not only produce large batches but also focus on the dynamic, personalised production of small batches.



SELCO WNA 8

- ✔ MAXIMUM PRODUCTIVITY ON ANY PATTERN
- ✔ EXCELLENT ARRAY OF CONFIGURATIONS
- ✔ TOTAL INTEGRATION WITH AUTOMATED LINE SYSTEMS
- ✔ OPTIMUM STRENGTH, ENABLING CONTINUOUS MACHINING OVER SEVERAL SHIFTS

OPTIMAL CUTTING QUALITY

Solid base structure which ensures perfect stability, maximum quality and long term reliability of machining operations.

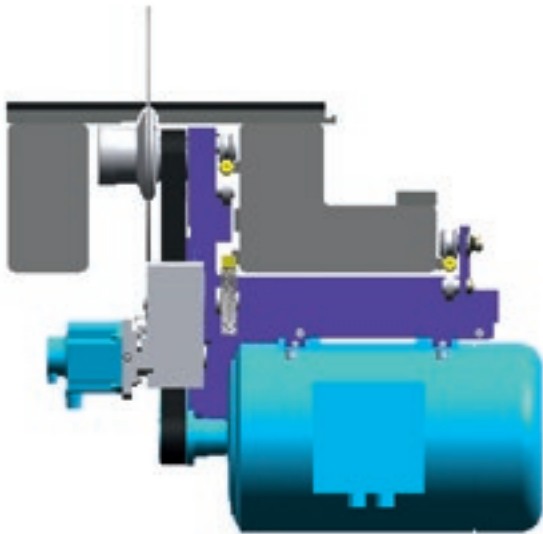

The optimal balancing and weight distribution on the two guides guarantees the total absence of vibrations and perfectly straight cutting action.

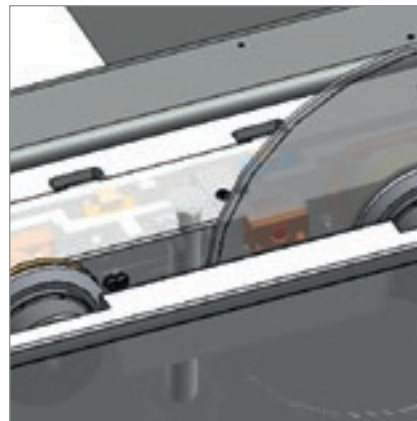

The blade deflections device controls the position and the number of revolutions of the blade, intervening to adjust the advance speed. **Maximum cutting quality, a longer blade lifespan, and reduced maintenance costs.**

The motorised vertical movement of the blade ensures **fast, precise** blade projection adjustment. The fixed motor of the main blade is not raised during the cut, and ensures the perfect balancing of the blade carriage.

TOP-QUALITY FINISHED PRODUCT



The double pressure beam has independent structure, enables the application of consistent, controlled pressure on the stack of panels to be cut. The absence of openings for the grippers creates a real airtight chamber for trim cuts, with an efficient vacuum for the removal of dust.

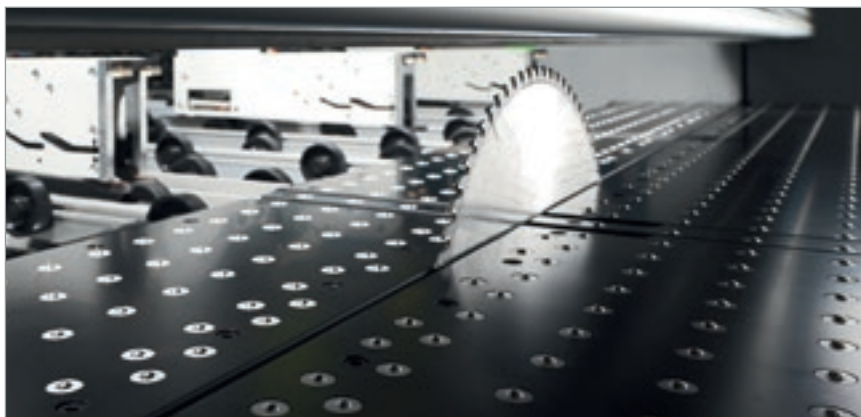

Air-cushioned working surface to handle delicate materials. In addition, this characteristic ensures the surface next to the blade is kept constantly clean.

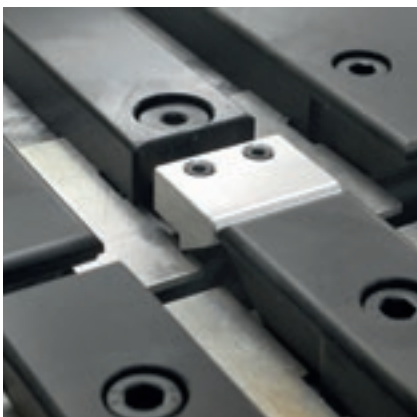

Front and rear rip trims are disposed of by means of a dedicated and fully automated dump table with independent rollers.

Cut line closure system, to prevent rip trim cuts from falling into the machine and fouling the blade path.

MACHINING OPERATION PRECISION

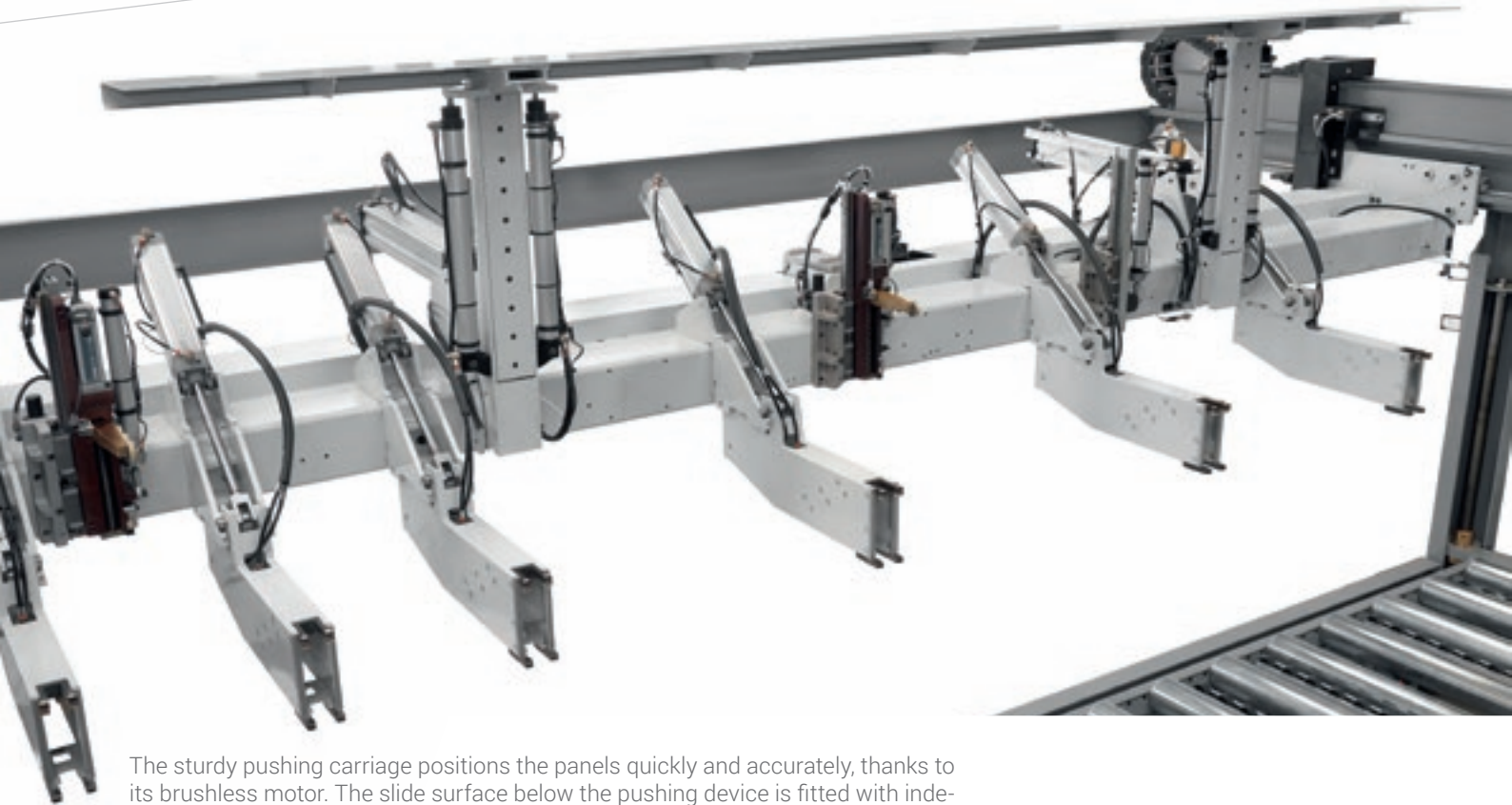

The sturdy pushing carriage positions the panels quickly and accurately, thanks to its brushless motor. The slide surface below the pushing device is fitted with independent rollers to avoid marking delicate surfaced panels.

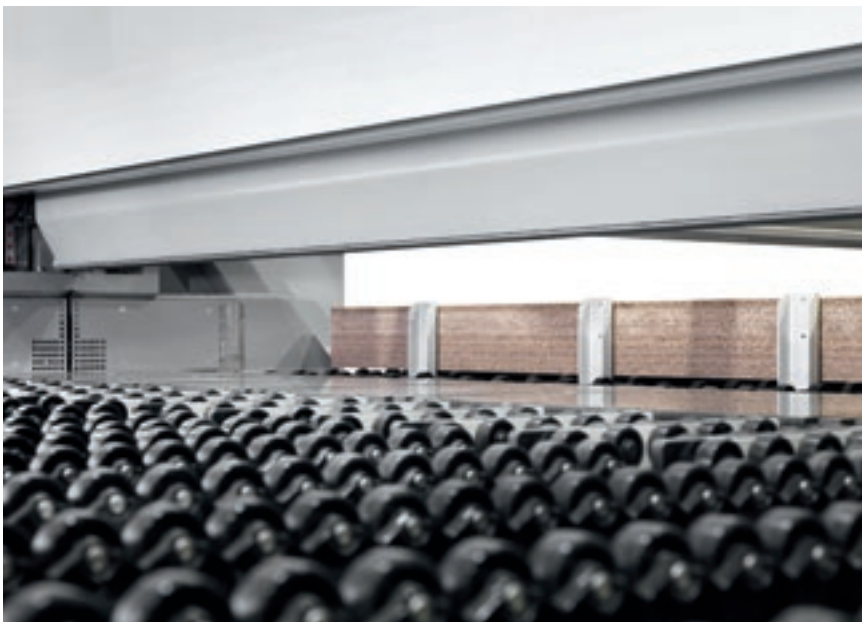

Powerful front aligners align the book of panels against the pushing points.

The slide surface is fitted with independent idle rollers to avoid any frictions on panels surfaces.

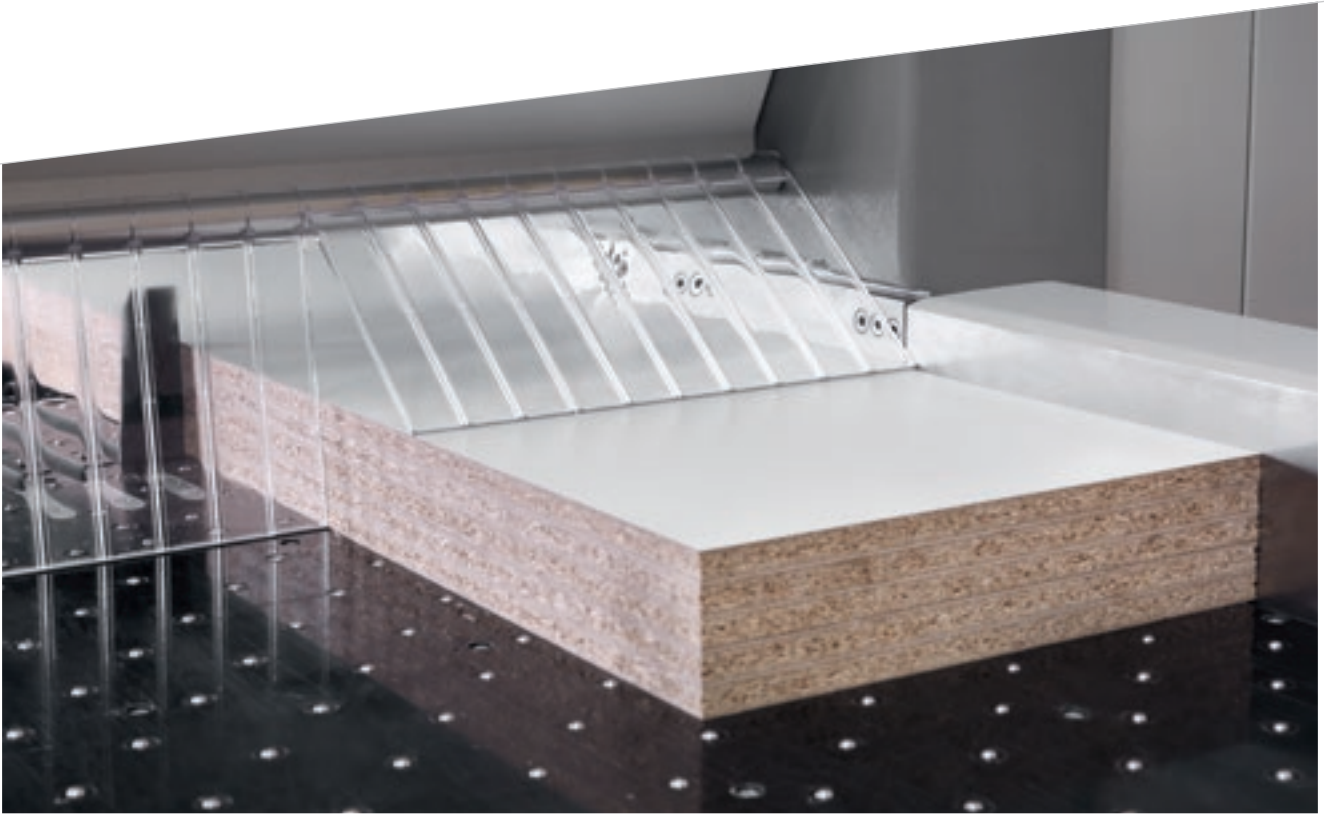

Side alignment stop integrated in the cross cut blade carriage. Its features enable the perfect alignment of even the thinnest and/or most flexible panels, reducing cycle time to a minimum.

A SOLUTION TO ANY REQUIREMENT



Thin panels can be loaded from the lifting table, using independent floating pushing points that are electronically controlled. A specific logic together with the front pop-up stops prevent the risk of misfeeding (by means of attrition) those panels that don't belong to the book being fed.

QUICK SET-UP TIMES

Patented systems for quick
and easy adjustments.



The “**Quick change**” system is the quickest, most ergonomic and safest device for changing blades without using tools.

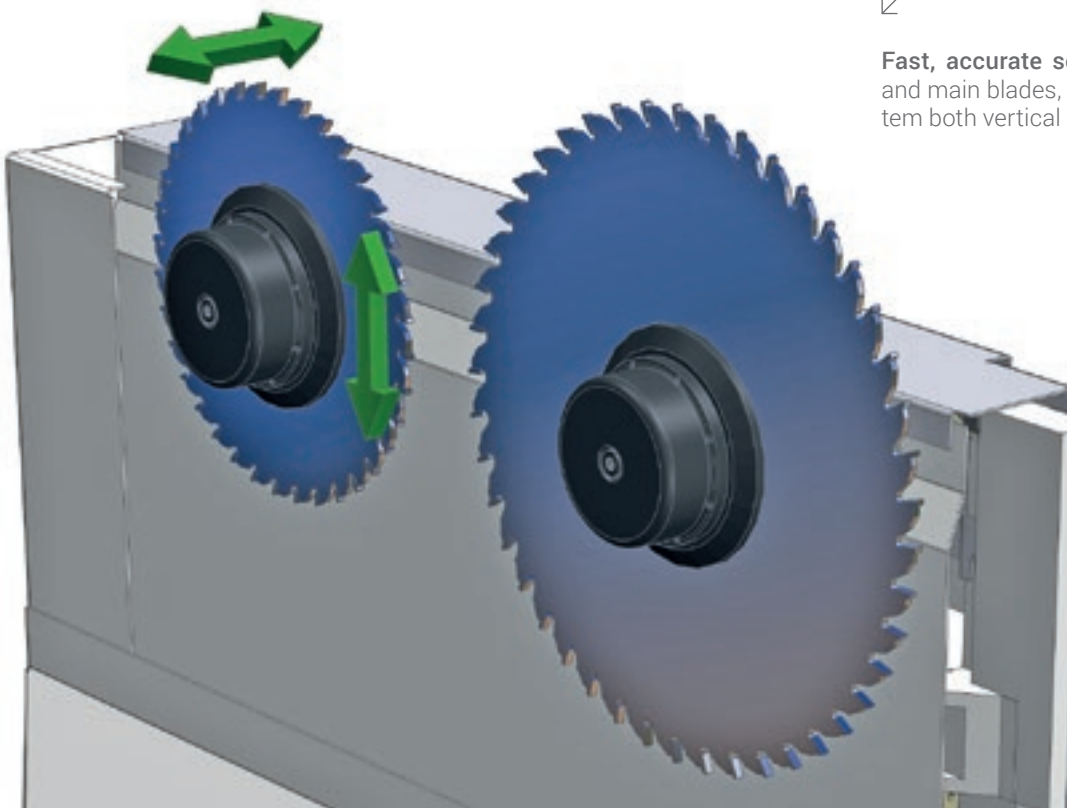

Fast, accurate setting of the scoring and main blades, using the Digiset system both vertical and horizontal.



Thanks to the system for the automated change of the main blade and the relevant software, the blade can be changed in a fully automated manner in just a few seconds, ensuring precise adjustment and reducing cycle times at the same time.

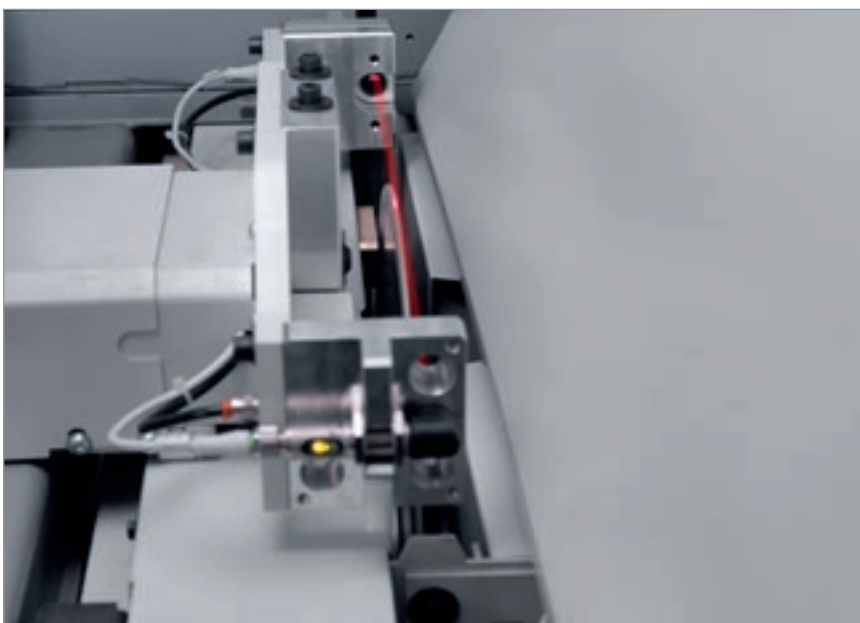

Automatic alignment. The patented system automatically aligns the scoring blade in seconds, which completely eliminates test cuts, reduces set-up time which increases efficiency and reduces production costs.

MULTI PUS HER

SIMULTANEOUS MULTIPLE ACTION

Significant reduction of processing times thanks to the possibility of combining the grippers with any type of cutting patterns in a single cycle.

System for performing simultaneous transverse cuts due to the two fully independent pushing devices and two completely independent motorless grippers. This mechanism changes distance between the two pushing devices and therefore their working field.

 **BIESSE**

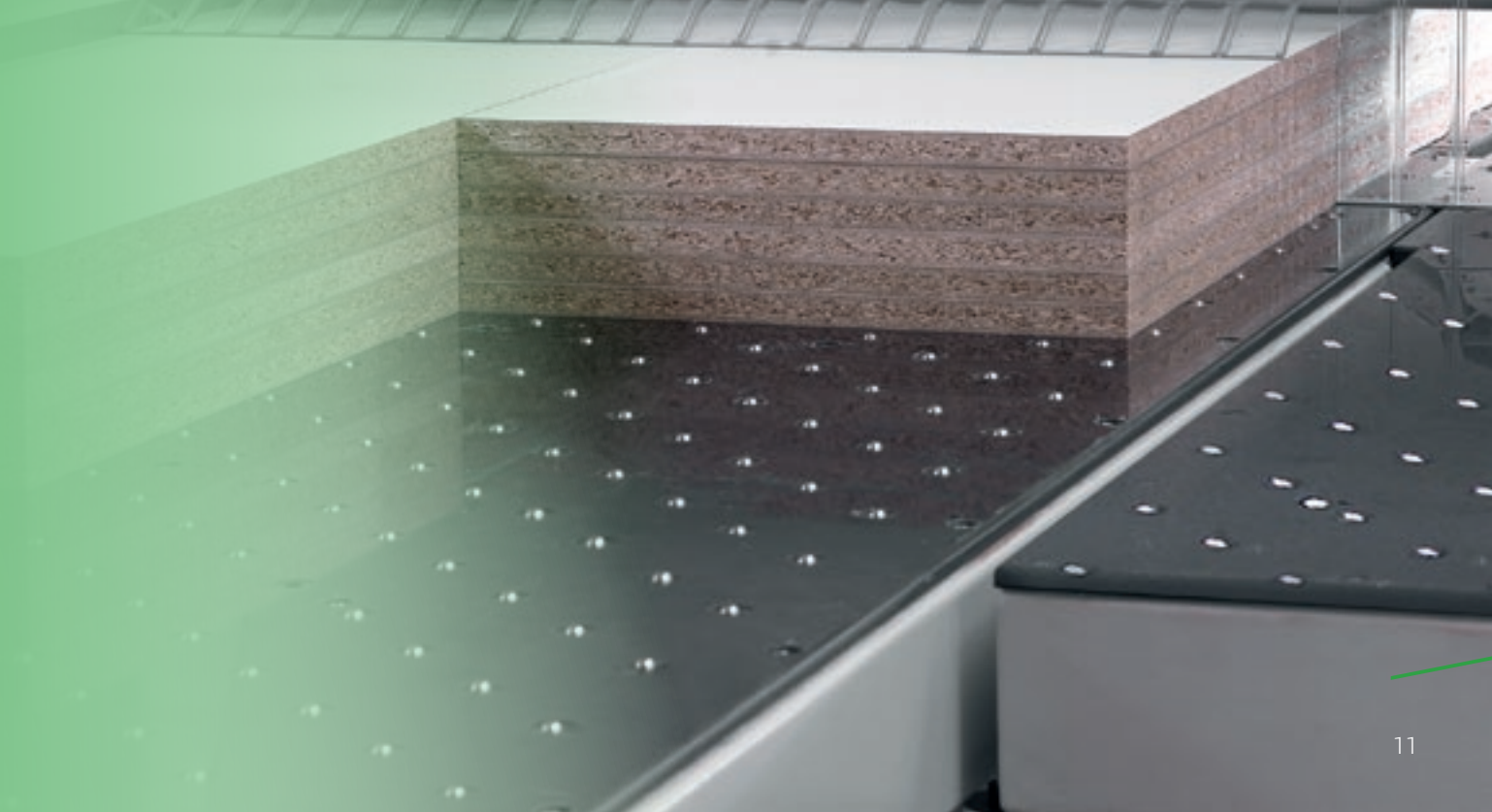
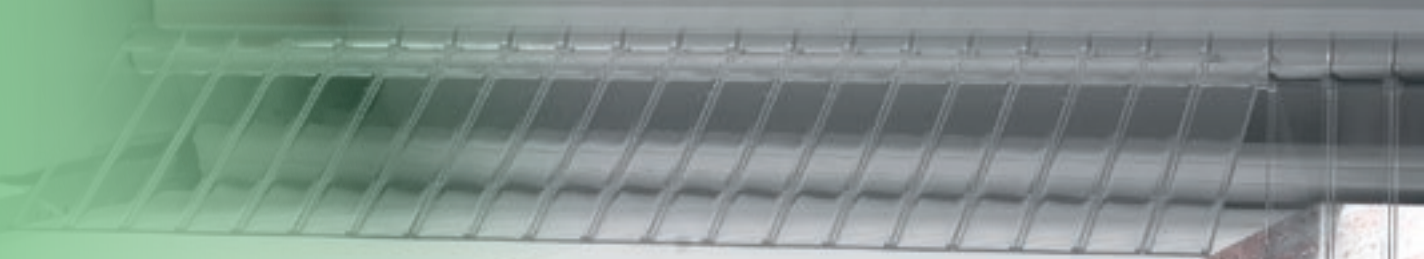

MAXIMUM PRODUCTIVITY ON ANY PATTERN

A wide range of configuration possibilities
to process efficiently a variety of cutting patterns.



Depending on the cutting pattern, the two idle grippers can link up (either individually or together) with the two pushing devices.



Differentiated cross-cut, also for narrow strips.

The two cutting stations can execute cutting patterns completely independently, thanks to the presence of an intermediate zone that can accommodate a whole panel. Both areas are fully covered in independent rollers to preserve the panel's surface.



REDUCED PANEL LOADING AND PARTIAL BUNK UNLOADING

Special solutions for handling stacks and feeding and unloading panels available upon request.



Double-level infeed conveyor. Thanks to the reduced footprint, which utilises height, the double-level infeed conveyor enables the optimisation of space and is perfectly suited to production sites that cannot accommodate two conveyors side by side.



Infeed conveyors with free-running or powered rollers allow the side and/or rear loading/unloading of panel stacks.



The lift table consists of a strong frame which is equipped with a special structure to load the pack of panels directly by forklift.

LOADING AND UPLOADING OPTIMISED FOR LARGE VOLUMES



The (patented) rotating station rotates the stack of panels, maintaining the alignment with the point of reference both before and after rotation. Panel clamping devices avoid the misalignment of the stack during the rotation phase.



Front aligners to align the boards in the width directly on the turn station unit.

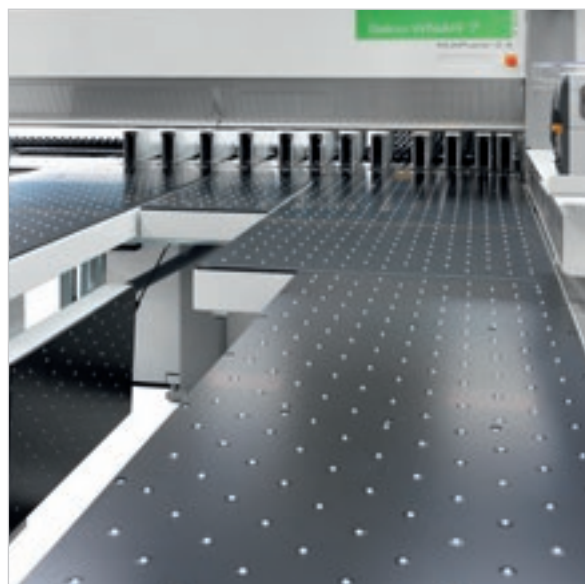

Wide range of configuration options to facilitate panel unloading.

PRODUCTION LINES

COMPETITIVE CUSTOMISATION

Biesse Systems is a team of highly trained engineers for large scale production processes. Biesse Systems offers integrated cells and systems that are capable of maximising customer competitiveness by combining mass production techniques with a high degree of customisation to meet customers' exact requirements.

Made-to-measure turnkey factories, plus the integration of Biesse Group solutions with complementary software and machinery, with over 1000 systems installed worldwide.



EASY TO USE, WITH OPTIMISED MACHINING OPERATIONS

The OSI (Open Selco Interface) numerical control guarantees the management of the execution of cutting patterns, and optimizes all movements relative to controlled axis (i.e. Pusher and Saw Carriage, pressure beam, blade height). It ensures the blade protrudes from the book to the correct degree during sectioning, and calculates the most suitable cutting speed on the basis of the book height and trim cut width. It helps ensure the best cutting quality at all times.

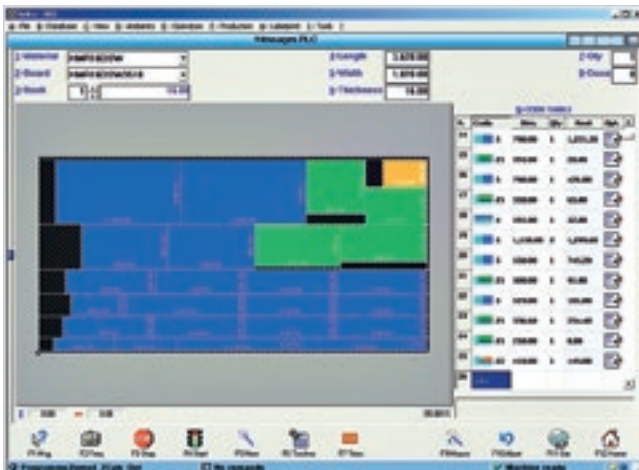

Easy cutting pattern programming.



Graphic simulation in real time, with messages and information for the operator.

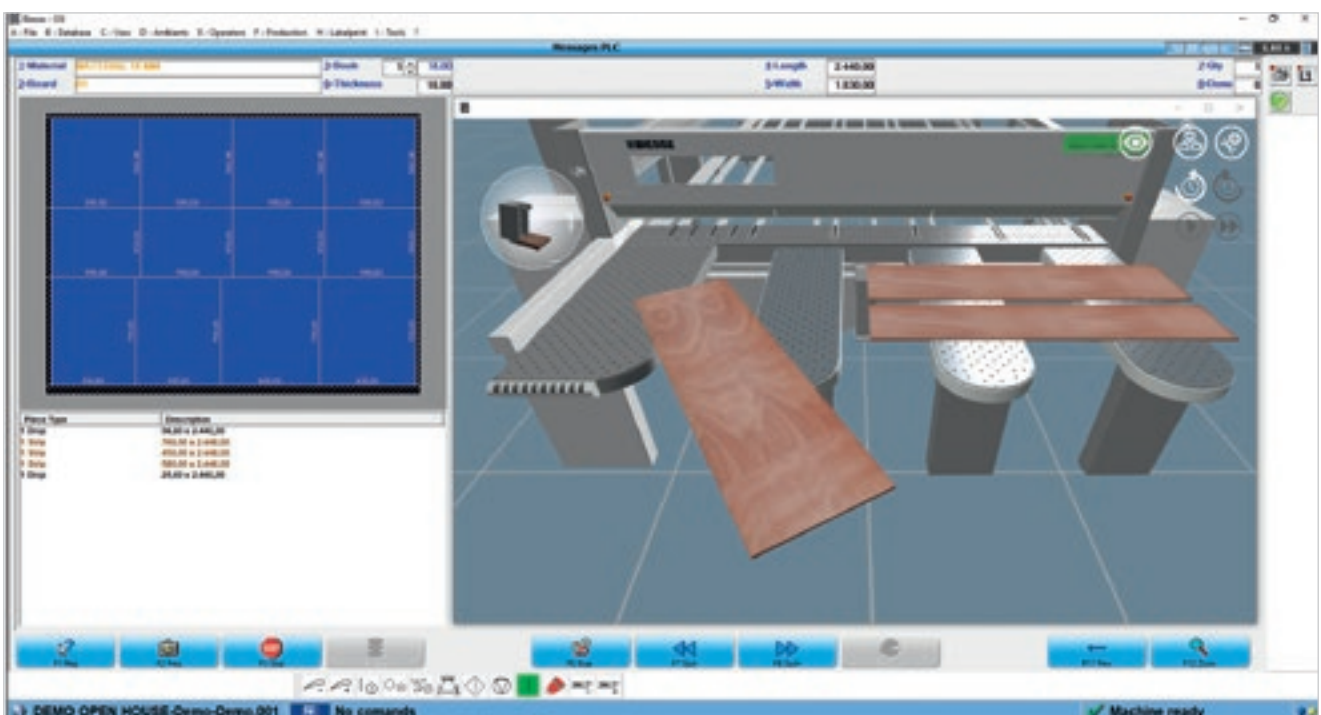



Interactive program for the quick, easy execution of cuts and grooves, even on recycled panels.

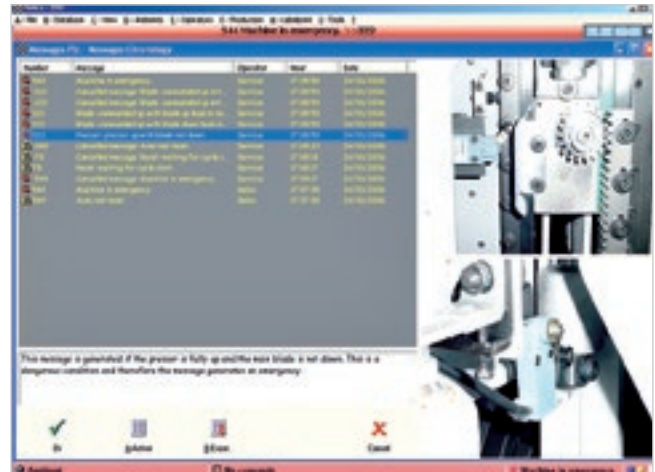

An effective diagnosis and troubleshooting program provides complete information (photos and text) to ensure that any problems are quickly resolved.

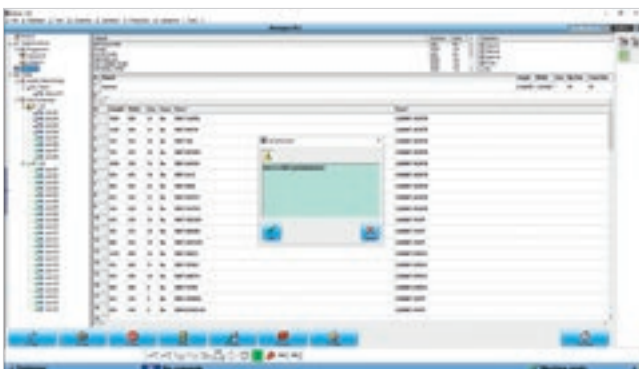

Quick Opti

Simple, intuitive software for optimising the cutting patterns directly on the machine.*

Labelling.

A special software creates individual labels and prints them in real time, on the machine. The information available can also be printed in bar code form.



SOFTWARE FOR THE SMART, ASSISTED MANAGEMENT OF CUTTING PATTERNS



B_OPTI IS THE SOFTWARE FOR OPTIMISING CUTTING PATTERNS, DEVELOPED ENTIRELY BY BIESSE. BASED ON THE LIST OF PIECES TO BE PRODUCED AND THE PANELS AVAILABLE, IT CAN CALCULATE THE BEST SOLUTION TO MINIMISE MATERIAL CONSUMPTION, SECTIONING TIMES AND PRODUCTION COSTS.

- Simple, user-friendly interface.
- Excellent reliability of the calculation algorithms for production batches in small and large companies.
- Automatic import of the cutting list generated by the software for the design of furniture items and/or ERP management systems.



CAN BE FULLY INTEGRATED WITH AUTOMATED LINE SYSTEMS



Lifter
Bridge unloader for cutting cells.



Winstore
Automated solution for cutting cells loading.

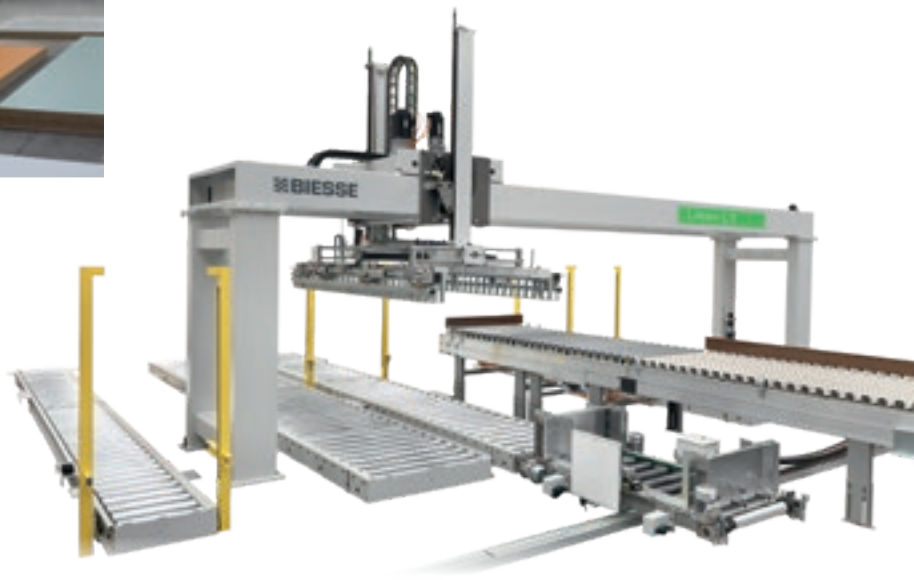

Cutting system with automated unloading for large batches.

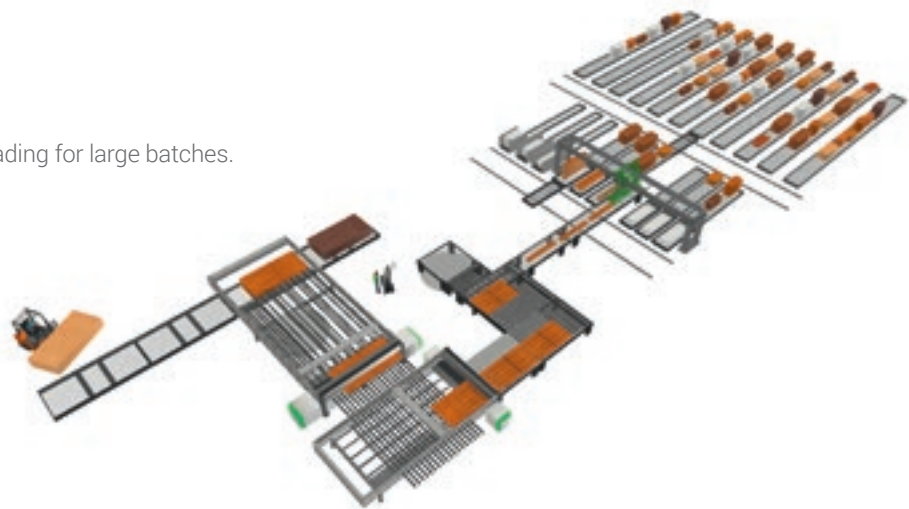

BIESSE CAN PROVIDE SPECIFIC SOLUTIONS WHICH ARE TAILORED TO MEET YOUR SPECIFIC PRODUCTIVITY, AUTOMATION AND SPACE REQUIREMENTS.

TECHNICAL SPECIFICATIONS

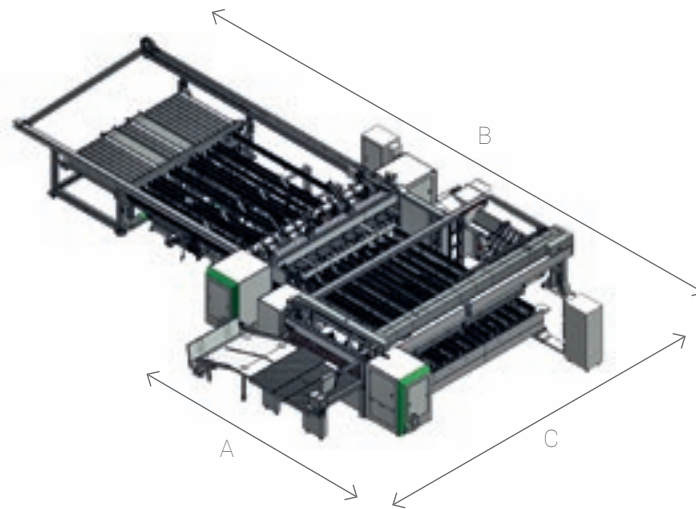

SELCO WNA 830-850

		4500 X 2200	4500 X 3000	5900 X 2200	5900 X 3000
A	mm/inch	6040/238	6540/257	6040/238	6540/257
B	mm/inch	14220/560	16320/642	14220/560	16320/642
C	mm/inch	9680/381	9680/381	11080/436	11080/436

SELCO WNAR 830-850

		4500 X 2200	4500 X 3000	5900 X 2200	5900 X 3000
A	mm/inch	6040/238	6540/257	6040/238	6540/257
B	mm/inch	16740/659	18320/721	17620/694	16320/642
C	mm/inch	9680/381	9680/381	11080/436	11080/436

		830	850
Maximum base projection	mm/inch	177/6.9	192/7.5
Main blade motor	kW	30	37
Scoring blade motor	kW	2.2	
Blade carriage drive		brushless	
Blade carriage speed	m/min - ft/min	1 - 160/3.2 - 525	
Pushing device drive		brushless	
Rip pusher device speed	m/min - ft/min	90 - 46	
Cross pusher device speed	m/min - ft/min	90 - 46	
Work table height	mm/inch	1165	
Work table height	mm/inch	830/33 - 730/29 per 5900/232	
Pneumatic requisites	bar	6.5 - 7	
Average compressed air requirements	NI/min	2860 (WNA) - 3000 (WNAR)	
Suction system	mc/h	17760 (26 m/s)	

The technical specifications and drawings are non-binding. Some photos may show machines equipped with optional features. Biesse Spa reserves the right to carry out modifications without prior notice.

Weighted sound pressure level A in: Operator workstation A dB(A) 85.3. Loading unloading position B dB(A) 84.8. Uncertainty of measurement K = 4 dB (A).

The measurement was carried out in compliance with UNI EN ISO 3746, UNI EN ISO 11202 and subsequent modifications. The noise levels indicated are output levels and do not necessarily represent safe operational levels. Even though there is a relation between emission levels and exposure levels, this cannot be used reliably to establish whether or not further precautions are necessary. The factors determining the actual noise levels to which the operative personnel are exposed to include the length of exposure, the characteristics of the work environment, other emission sources, i.e. the number of machines and machining operations in the vicinity. In any case, this information will help the machine user to better assess the danger and risks involved.

SOPHIA

GREATER VALUE FROM MACHINES

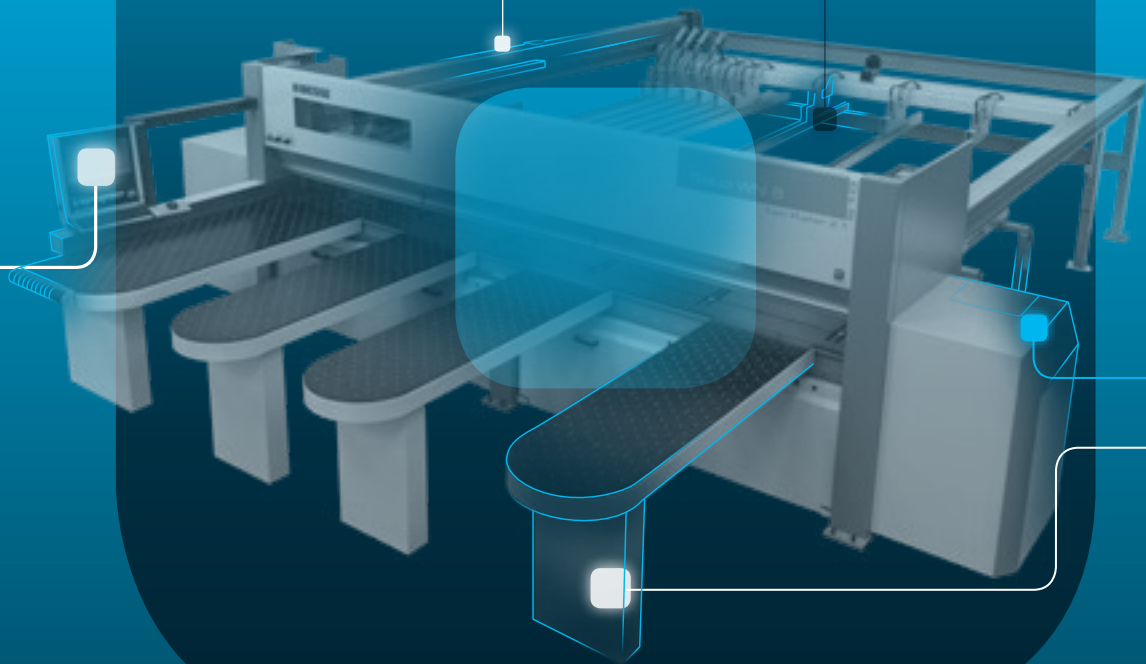

SOPHIA is the IoT platform created by Biesse in collaboration with Accenture which enables its customers to access a wide range of services to streamline and rationalise their work management processes.

It allows alerts and indicators to be sent to the customer in real time, in relation to production, the machines used and the type of process carried out. These are detailed instructions for more efficient use of the machine.

□ **10% CUT IN COSTS**

□ **50% REDUCTION
IN MACHINE DOWNTIME**

□ **10% INCREASE
IN PRODUCTIVITY**

□ **80% REDUCTION IN PROBLEM
DIAGNOSTICS TIME**

**SOPHIA TAKES THE INTERACTION BETWEEN
CUSTOMER AND SERVICE TO A HIGHER LEVEL.**

iOT
SOPHIA

IoT - SOPHIA provides a comprehensive overview of the specific machine performance features, with remote diagnostics, machine stoppage analysis and fault prevention. The service includes a continuous connection with the control centre, the option of calling for assistance from within the customer app (such calls are managed as priorities), and an inspection visit for diagnostic and performance testing within the warranty period. Through SOPHIA, the customer receives priority technical assistance.

PARTS
SOPHIA

PARTS SOPHIA is the easy new, user-friendly and personalised tool for ordering Biesse spare parts. The portal offers customers, dealers and branches the chance to navigate within a personalised account, consult the constantly updated documentation of the machines purchased, and create a spare parts purchase basket indicating the real time availability in the warehouse and the relative price list. In addition, the progress of the order can be monitored at all times.

 **BIESSE**

in collaboration with  **accenture**

CUSTOMER CARE IS WHO WE ARE

SERVICES is a new experience for our customers, to offer not just excellent technology but the added value of an increasingly direct connection with the company, the professionals who work there and the experience they embody.



ADVANCED DIAGNOSTICS

Digital channels for remote interaction online 24/7. Always ready to intervene on-site seven days a week.



A WORLDWIDE NETWORK

39 branch offices, over 300 certified agents, retailers in 120 countries, and spare parts warehouses in America, Europe and the Far East.



SPARE PARTS AVAILABLE IMMEDIATELY

Identification, shipping and delivery of spare parts for every need.



EVOLVED TRAINING OPPORTUNITIES

Lots of on-site, online and classroom training modules for personalised growth.



VALUABLE SERVICES

A wide range of services and software packages to help our customers achieve continuous improvements in performance.

AN EXCELLENT LEVEL OF SERVICE

+550

HIGHLY SPECIALISED
TECHNICIANS AROUND
THE WORLD, READY TO HELP
CUSTOMERS WITH EVERY
NEED

90%

OF MACHINE DOWN CASES
WITH RESPONSE TIME
UNDER 1 HOUR

+100

EXPERTS IN DIRECT
CONTACT THROUGH
REMOTE CONNECTIONS
AND TELESERVICE

92%

OF SPARE PARTS ORDERS
FOR MACHINE DOWNTIME
PROCESSED WITHIN 24
HOURS

+50.000

ITEMS IN STOCK IN THE
SPARE PARTS WAREHOUSES

+5.000

PREVENTIVE MAINTENANCE
VISITS

80%

OF SUPPORT REQUESTS
SOLVED ONLINE

96%

OF SPARE PARTS ORDERS
DELIVERED IN FULL ON TIME

88%

OF CASES SOLVED WITH
THE FIRST ON-SITE VISIT

MADE WITH BIESSE

FOR A REVOLUTIONARY BUT CONSCIOUS DESIGN

Conscious design that understands society and skilfully changes it for the better. That's the mission at the heart of Lago, a furniture company founded in 1976 with two simple concepts encoded in its DNA: curiosity and doing things well.

The common ground for the Biesse Group and Lago, which reinforces the historic partnership between the furniture and carpentry sectors, is the Alliance project: a collection of brands, people and businesses that have decided to join the design company from Veneto on a journey of respect for our planet, ourselves and our future. The historic partnership is borne out by the innovative production plant that Biesse developed with Lago, completely restructuring the manufacturing site. The result is the inclusion of a new Batch One facility within the existing production context, in the spirit of personalisation, speed and flexibility.

The facility has a new square-edging cell with Stream MDS and Winner W1, a new drilling cell with Skipper 130 and a new Selco WNR 650 sizing centre connected to Win-

store 3D K1, which intelligently manages all the material to be processed.

"Including the 'batch one' process bolsters the 'just in time' objective set by Lago, reducing the warehouses needed for semi-finished products and raw materials, as well as reducing scrap material and elevating product quality. What's more, it improves efficiency, reduces time to delivery and offers complete control over the production flow," explains Mauro Pede, Biesse Systems Sales Director.

"The new investments have led us to a new productive flexibility that we will continue to implement, for a renewed production speed and even greater customisation of the range," adds Daniele.

Carlo Bertacco echoes the sentiment, "We are completing a 2,500 m2 expansion, to be even faster and more flexible while maintaining the extremely high level of quality that Lago is known for. It's an equation that relies heavily on technology: I'm referring to one of the particularly valuable machines we purchased from Biesse – a small 'Brema Eko' – not only is it extremely flexible, it allows us

to greatly simplify some steps, since we can process painted pieces without worrying about damaging them.

It's proof that with clear ideas and a precisely organised work flow one can find simple solutions that produce excellent results."

**LAGO BELIEVES
THAT DESIGN MUST
BE GUIDED BY MAN,
BY HUMANITY AND
EMPATHY**



Daniele Lago
Founder



THE BIESSE SIZING RANGE

FLEXIBLE CUTTING



NEXTSTEP



SELCO WN 6 ROS

SINGLE-LINE BEAM SAWS



SELCO WN 2



SELCO SK 3



SELCO SK 4

SINGLE-LINE BEAM SAWS



SELCO WN 6



SELCO WN 7

CUT TO SIZE ANGULAR PLANTS



SELCO WNA 6



SELCO WNA 7



SELCO WNA 8

LIVE THE EXPERIENC

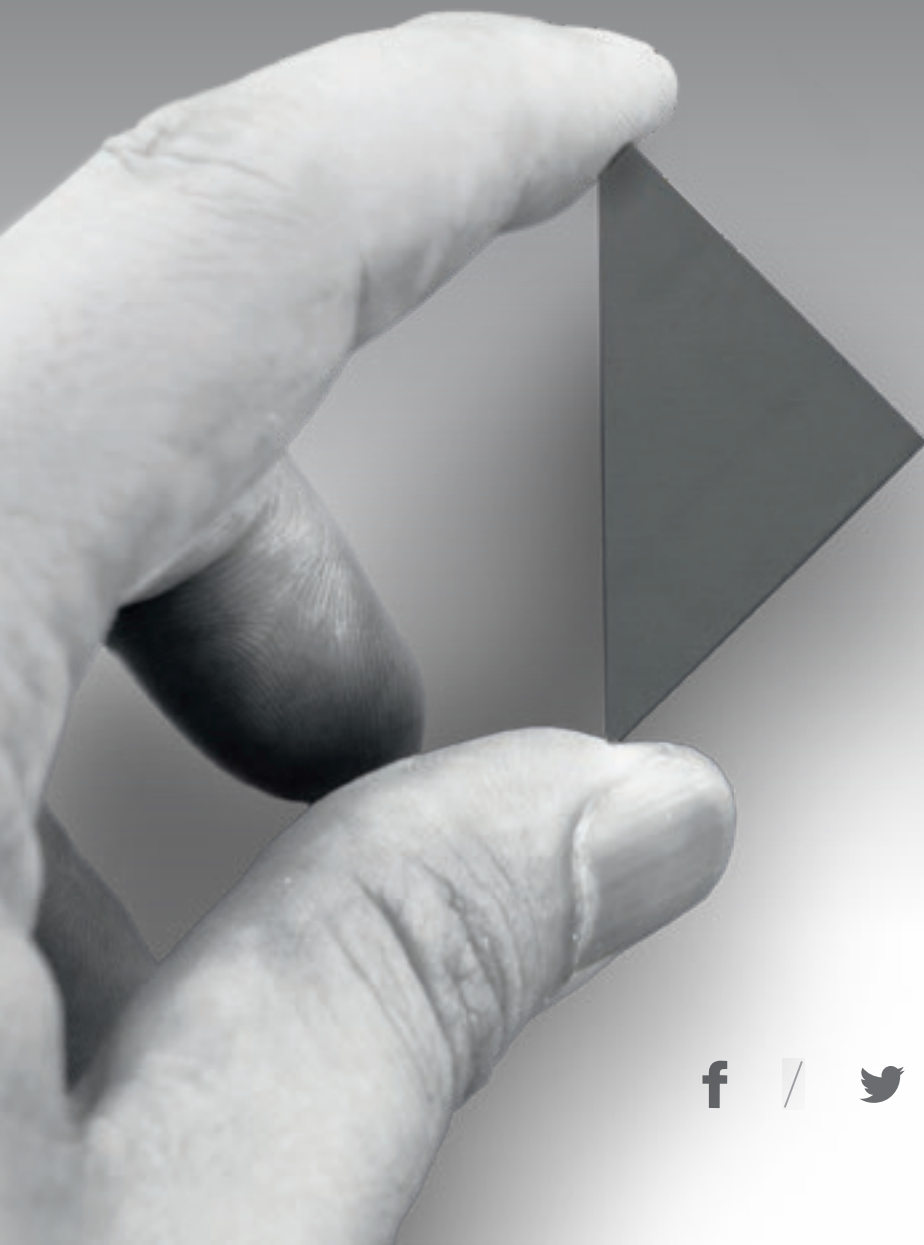

BIESSEGROUP.COM

E



Interconnected technologies and advanced services that maximise efficiency and productivity, generating new skills to serve better our customer.

LIVE THE BIESSE GROUP EXPERIENCE AT OUR CAMPUSES ACROSS THE WORLD

 **BIESSEGROUP**

