

Panel dividing saws of the 3 series  
HPP 300 | HPL 300 | HKL 300





## The 3 series – flexible, individual and exactly the right solution for you

Whether it's an HPP, an HPL or an HKL: The standard models of the 3 series have everything a panel dividing saw needs. No less, but also no more. That is because you can decide what more you need and simply choose the appropriate optional features. This means you can custom configure **YOUR SOLUTION** and invest no more than is necessary.

Find out more here: [www.homag.com](http://www.homag.com)

### VIDEO:



[The 3 series](#)

### Contents

- 04 HPP 300 profiLine
- 06 HPL 300 profiLine
- 08 HKL 300 profiLine
- 10 Standard features
- 20 Standard features for HPL and HKL models only
- 22 Optional features
- 47 Technical data

## HPP 300 profiLine

With the HPP 300 profiLine you get a compact and powerful single saw that offers impressive versatility. These properties make it ideal for connecting to an automatic HOMAG panel storage system.

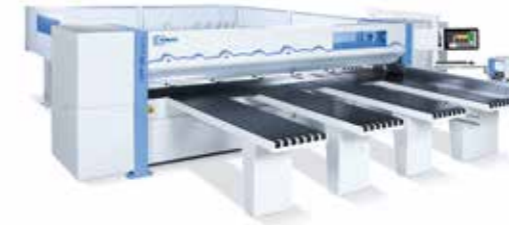

### THE HIGHLIGHTS

- 80 mm saw blade projection, 95 mm as option
- Ergonomic table height of 920 mm
- Easy operation
- Reliable and efficient



## HPL 300 profiLine

This model sets you up for really big jobs. The integrated lifting table for automatic feeding speeds up your production processes by a considerable margin, particularly if you frequently cut panels made from the same material or in books.

### THE HIGHLIGHTS

- Feed either from the back via the lifting table or manually from the front for individual panels
- High material throughput for book cutting and series cutting
- 80 mm saw blade projection, 95 mm as option
- Ergonomic table height of 920 mm



## HKL 300 profiLine

The HKL 300 profiLine angular saw unit is the top model in the 3 series – designed for maximum precision in continuous operation. It addresses the needs of trade and industry alike. The system cuts entire books of panels as accurately as it does single panels. Fully automatically and with long-term reliability.

### THE HIGHLIGHTS

- Compact yet powerful angular saw unit
- Ideal for individual panels and small books of panels
- High quality cuts in record time
- 80 mm saw blade projection, 95 mm as option
- Machine tables equipped with air jets as standard feature

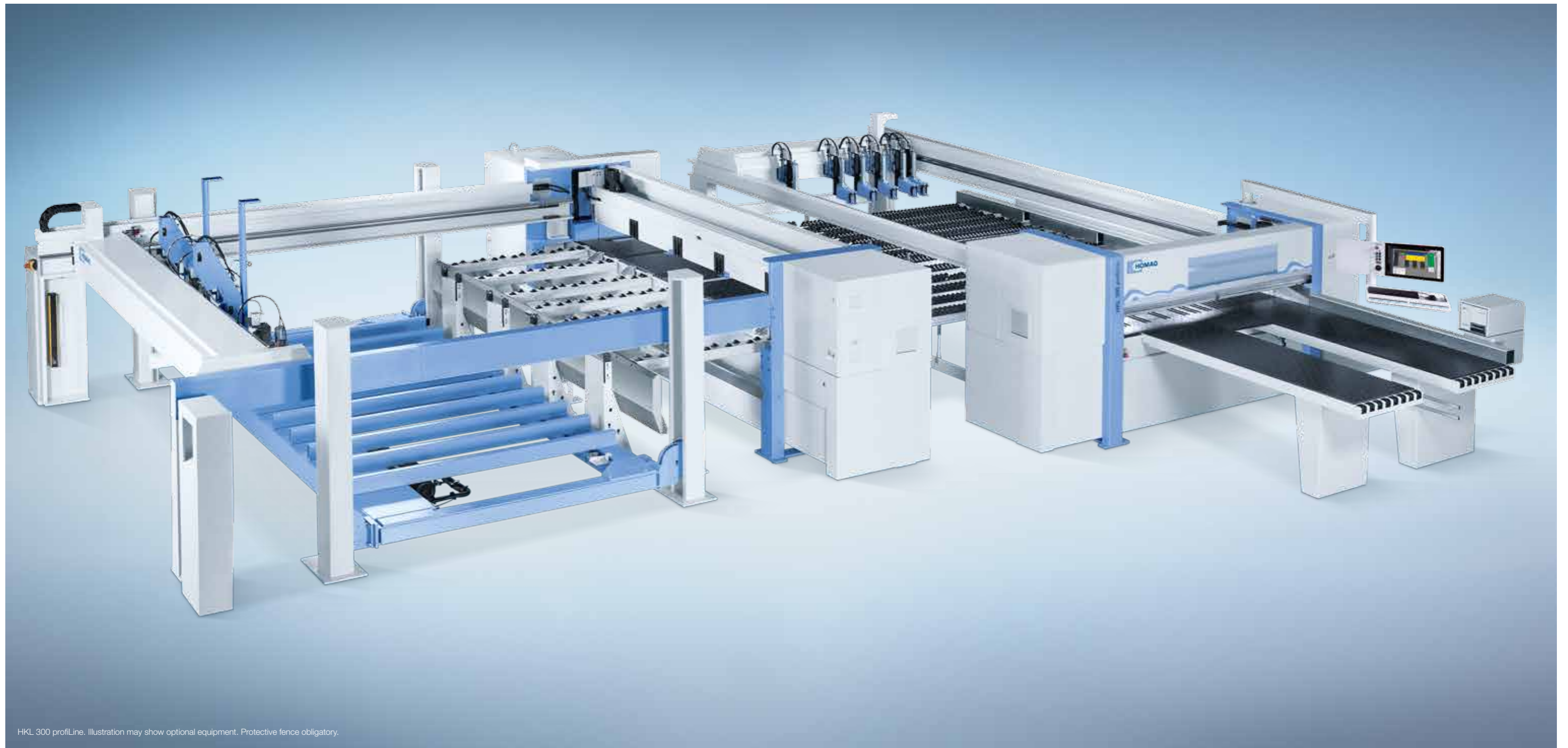

A man in a light-colored polo shirt and brown work apron is holding a large blue board with both hands. He is looking at the board with a focused expression. In the background, there is a large industrial machine, likely a saw, with a blue and white color scheme. The machine has a long, narrow table and a large blade. The man is standing in front of the machine, and the board he is holding is positioned vertically. The overall scene is a workshop or factory setting.

## Standard features

Even in the standard version, the saws in the 3 series offer the full range of technical features and can be put to flexible use, either as a standalone machine, linked to other machines or as part of a production line, depending on the production concept. This makes the 3 series the ideal solution for trade and industry in many applications.

**Good to know:**

- Equipped with the latest CADmatic 5 control software
- Extremely energy efficient thanks to intelligent ecoPlus technology
- Low maintenance, ergonomic and intuitive operation



## ecoPlus – because efficiency starts with the use of resources

Energy, time, material and personnel are all precious resources. Whoever conserves them increases productivity and saves costs. The ecoPlus technology from HOMAG helps you to achieve this aim, providing countless innovations that save energy and reduce your operating costs. What's more, ecoPlus reduces CO<sub>2</sub> emissions, thereby helping to protect the environment. A worthwhile investment twice over.

### VIDEO:



[ecoPlus](#)

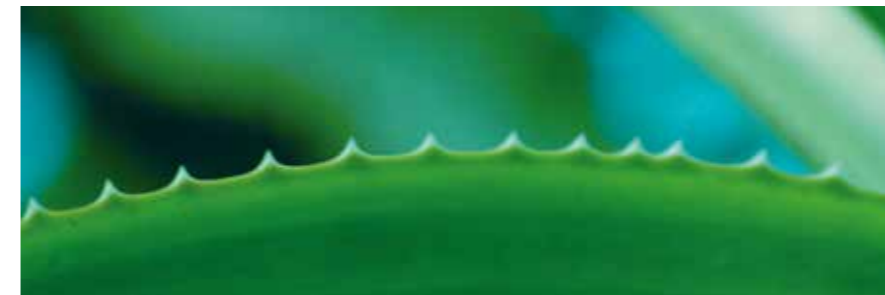

#### ecoPlus technology for maximum energy savings

- The standby button, a standard feature, puts the saw in an energy-saving standby mode at the touch of a button
- All models with IE3 motors
- Variable speed control by means of a modern bypass circuit for all models with frequency-controlled main saw motor
- Patented rocker raises just the main saw blade, while the motor remains in position – this saves energy
- The light sensor on the saw carriage has its own blower unit (option), which utilizes the air discharged from the main saw motor
- The pneumatic system in the saw carriage has been partially replaced by hydro-pneumatic components, thus cutting compressed air costs and enhancing precision
- The geometry of the saw carriage enables highly efficient extraction
- Intelligent optional features: the load-dependent means of controlling the strength of the air cushion – for example on the air cushion tables – means energy consumption is limited to only what is required
- All models are equipped with the energy monitor for consumption monitoring
- Less energy required thanks to optimized extraction
- Thin-kerf saw blades can be used on request, ensuring less waste among other benefits
- Numerous innovations for improved ergonomics and smooth production processes

**Find out more in the “ecoPlus” brochure.**

### WITH ECOPLUS, YOU SAVE:

Up to **20%** of energy\*

\* Compared to our older saws

## Peak performance is the result of numerous high-tech solutions

Speed, quality and precision during the cutting process can only be achieved if panel materials are moved quickly, gently and with a high level of accuracy. With the saws in the 3 series, numerous technologies work together like cogs to ensure this is the case — from program fence to pressure beam and clamps, all the way through to the patented side pressure device.



### Program fence for precision and dimensional accuracy

- Resistant to torsion and bending
- Electronically controlled
- Precision guidance on H-girder
- Electromagnetic measuring system guarantees a lifetime positioning accuracy of +/- 0.1 mm
- Measuring system involves no wear and no maintenance

### Rugged pressure beam for first-class cut quality

- Large-area pressure zone directly at the cutting line reduces material vibrations to a minimum
- Linear guide on both sides
- Toothed rack and pinion ensure the necessary parallel adjustment
- This results in accurate, clean cuts, for books too
- With height control on request (available as an option)



### Clamps

- Rugged clamps, all with two fingers
- Gentle positioning of material
- The bottom fingers of the clamps can be removed at any time to allow the clamp base to be cut in perfect alignment — a fast means of adjustment
- The clamping pressure can be adjusted (manually) to suit each particular material
- The short, rugged design allows material to be precisely held and guided more gently
- Irrespective of the book height, the top fingers of the clamps do not exert any leverage; instead, they are lowered horizontally and their entire contact surface rests on the material. This increases the working depth and ensures material is held firmly
- Designed for continuous, multi-shift operation



### Patented: central side pressure device

- Integrated directly in the saw carriage — shortens cycle times by up to 25% in comparison with conventional systems
- Infinitely variable adjustment of contact pressure — depending on panel thickness. This allows even thin panels, laminates or sensitive materials to be processed perfectly. Another key feature here is the book-height-dependent control of the contact pressure: the higher the book, the greater the pressure



### Chopping edge on the right-angled fence

With the help of the chopping edge, waste strips can be disposed of quickly and easily. The robust edge is within easy reach of the operator and ideally positioned on the right-angled fence, allowing waste to fall directly into the container for improved ergonomics.

### VIDEO:



[Central side pressure device](#)



[Chopping edge](#)



## The saw carriage: high performance, low consumption

Exceptionally smooth running, high precision and low energy consumption are the hallmarks of the saw carriage developed for the 3 series.



### One saw carriage, numerous benefits

- Torsion-resistant, rugged and resilient basic design of the steel plate body for maximum dynamics and precision
- Infinitely variable feed speed — for precision cutting of demanding materials
- Long-term accuracy of saw blade projection
- Fast, precise, low-wear and infinitely variable positioning of the main saw blade by means of linear guide system with rocker arm (patent)
- Energy saving feature: main saw motor is not raised
- Low-noise, maintenance-free main saw blade drive
- Spring-preloaded running wheels (optional) always in perfect contact with the guides
- Light sensor with blower unit (available as an option)
- The design of the saw carriage ensures excellent extraction results
- Postforming optional (page 38)

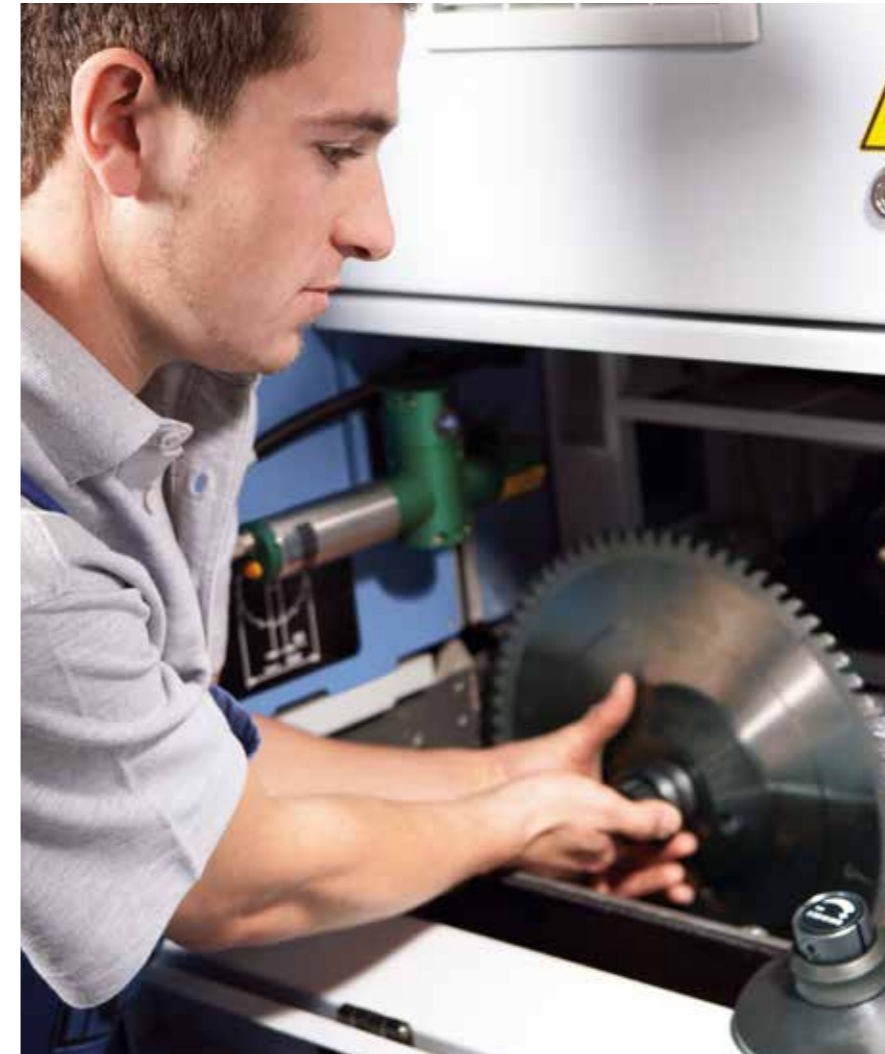

### Power-Loc system

Making it quick and simple to change the saw blade.

### VIDEO:



[Power-Loc](#)

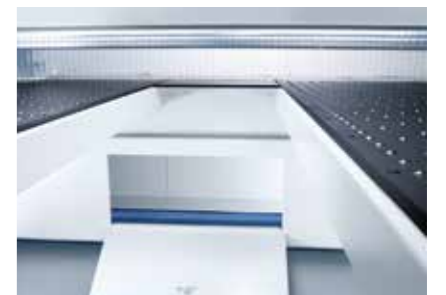
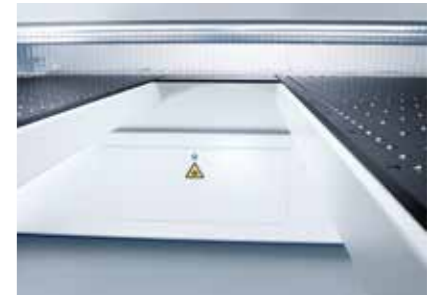

### Handy cleaning flap

Fast and convenient: The area under the saw carriage is easily accessible via flaps, allowing easy removal or vacuuming of cutting waste.



[Cleaning flaps](#)



## CADmatic 5 — intuitive to operate and open for digital networking

CADmatic 5 is the saw control system for today's networked world. Designed to tackle complex data streams yet nevertheless easy to use. This is ensured thanks to the intuitive operating concept and clear administrative functions. What's more, CADmatic 5 is open for communication with networked machines and software solutions via interfaces.

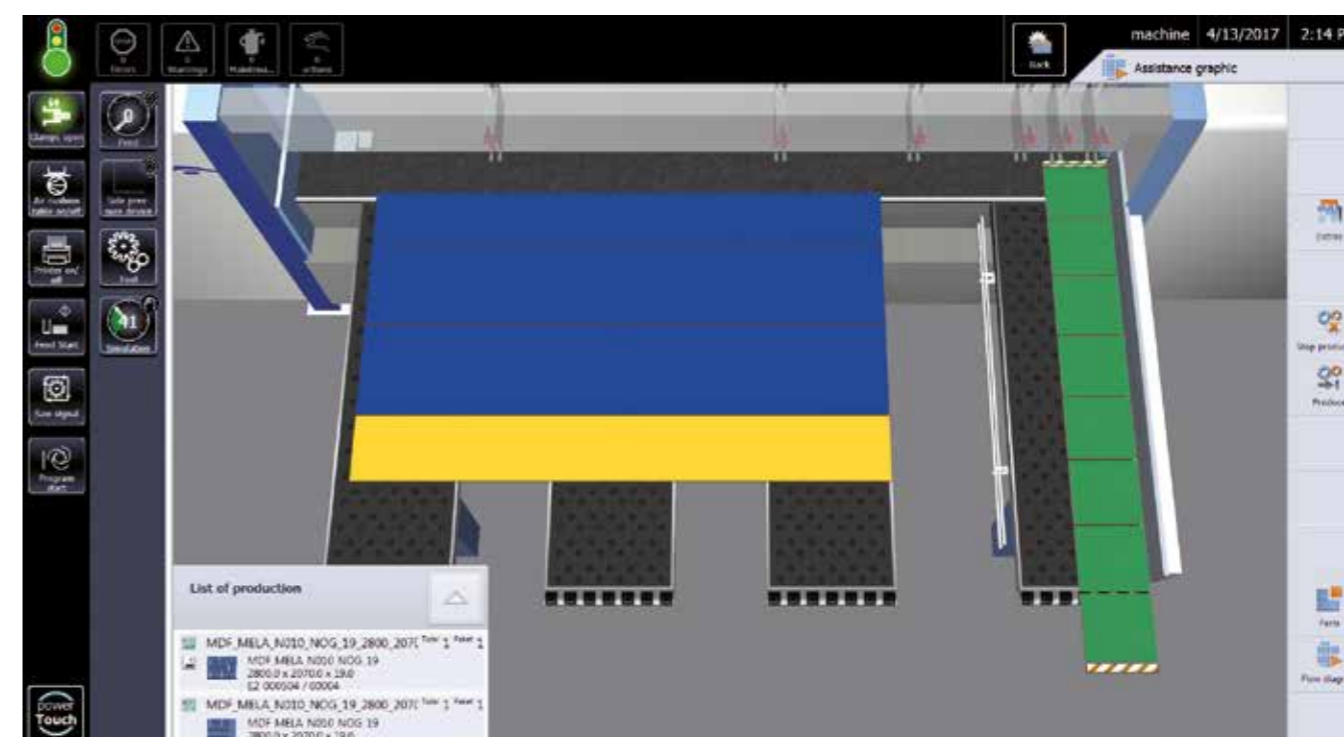

- 21" full-HD monitor with multitouch display in widescreen format
- The new 3D assistance graphic aids the operator
- powerTouch user interface
- Intuitively understandable operating software
- Simple handling via tapping/swiping and touch
- Quick to change between the individual sections
- Graphically supported diagnostics

Find out more in the "CADmatic" brochure.

### VIDEO:



[powerTouch](#)

## Even more technology — with the HPL and HKL 300

Panel dividing saws in the HPL and HKL series set themselves apart with their automatic feeding system and increased level of automation. In short: They work differently to the HPP 300 and require additional technical solutions, even in the standard version.



### Separate backing wall

The backing wall is not attached to the machine bed, ensuring precise cuts. This is because vibrations caused by the movement of stacks on the lifting table are not transferred to the machine bed.

### Powerful feeding system

- Panels are fed to the HPL and HKL via an electrohydraulic four-column lifting table
- Automatic determination of book height
- Equipped as standard with longitudinal profiles and sensing device
- Also suitable for thin materials from 9.5 mm upwards. If equipped with the micro-feed and hold-back device (optional features), suitable for materials from 3 mm upwards (page 26)
- Maintenance-free and no lubrication required

### Extra impetus for feeding

The automatically driven roller conveyor, integrated in the lift table, and additional roller conveyors to the side ensure fast stack changeover.



### Waste flap (for HKL only)

- The waste flap opens fully automatically when required and removes cutting waste from the rip saw
- Opens and closes in perfect coordination with the operating cycle of the system

### Outfeed device for the rip saw (for HKL only)

The outfeed device pushes the panel material onto the intermediate table and the trim onto the waste flap.



### Intermediate table for transferring to the cross-cut saw (for HKL only)

- Special motor-driven pushers ensure perfect cross transfer in a quick process
- Roller rails can be raised and lowered
- Lengthwise and crosswise alignment after transfer
- AB-BA system for mirror-image cutting
- Integrated headcut device

## Optional features

More technology for customized production down to the very last detail: These features allow you to supplement the functionality of your saw in line with your requirements — from adding a link to a storage system to performing custom cuts, all the way through to labeling and destacking. So you get exactly the solution you need.



## Feeding solutions from S to XXL

Manually transporting materials from storage to the saw is extremely complex and time consuming. This process also requires a significant amount of space and is anything but gentle on materials. All the better then that tailored automation solutions are available from HOMAG for virtually all sizes of business — from simple feeding solutions via the lifting table to a large-scale storage control connection.



### Large-scale storage control connection

HOMAG offers a range of high-performance solutions for large businesses and customers with strict automation requirements. What's more, the saws in the 3 series are also open for connection to virtually all storage systems. To ensure the very highest level of performance.

Find out more in the “Handling solutions for cutting applications” brochure.

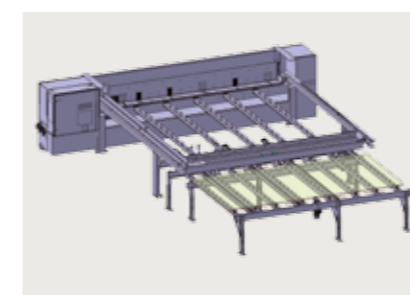

### Feed-stacking table with integrated infeed

When linked to a simple storage system, the saw has to stop working briefly when a new panel is fed. The feed-stacking table now ensures smooth, faster workflows: While one panel is still being cut, the storage system can already deposit the next panel(s) on the feed-stacking table with integrated infeed.

- Ideal in combination with the HOMAG panel labeling system (page 35)
- Can be retrofitted
- Plug & Play: easy add-on
- Without alignment
- Perfectly matched to the saw (height, width, roller rails)
- Virtually no more idle time



### Easy2Feed — automatic feeding with an affordable price tag (for HPP only)

With Easy2Feed, you save both time and space. This optional feature is particularly ergonomic and can be retrofitted at any time — without the need for additional space. The core element is a compact scissor lift table, which can be comfortably loaded by forklift truck.

- Panels upwards of 9.5 mm thickness can be fed
- Maximum panel size: 3100 x 2200 mm
- Stack height: 800 mm (in pit)
- For material that can be push-fed

### VIDEO:



[Easy2Feed](#)

### Low-cost storage system integration

Not everyone who wants to work rationally and efficiently has to opt for the large-scale solution. HOMAG also offers storage control connections for small, up-and-coming trade businesses. These connections can be used to noticeably speed up your processes and save you money twice over.

- Small footprint
- Attractive price
- Movable in x and y directions
- Saw and storage system perfectly coordinated
- Perfect handling — even with just one machine operator
- Easy, ergonomic operation
- “Storage system controlling the saw” possible. With this system, the production sequence can be changed by the storage system if making the change will speed up the production process as a whole

# Extra tools for demanding materials

Exceptional materials require exceptional technical solutions. With the 3 series, these tools are available in abundance, for example for thin panels.



- Hold-back device (for HPL and HKL only)**
- 1 **Micro feed in combination with the**
  - 2 **hold-back device for thin boards from a thickness of 3 mm upwards**

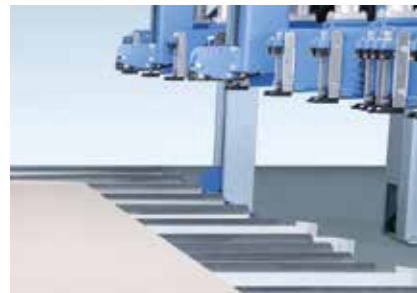

**Micro feed for thin panels**

The micro feed option allows thin panels from 6 mm upwards to be pushed onto the rear machine table (provided that their properties meet HOMAG specifications). Book height is measured by a non-contact, electromagnetic measuring system which is completely maintenance-free.

**Extra-long cutting lengths**  
The HPP 300, HPL 300, and HKL 300 are also available with 5 600 mm cutting length on request.

**VIDEO:**



[Micro feed](#)



**Soft Touch for pressure-sensitive material**

As the range of materials increases, so too do the requirements: Pressure-sensitive lightweight panels, composite panels and plastic panels need to be processed with increasing regularity. HOMAG has a range of solutions in its portfolio designed to meet these requirements. Simply ask your customer advisor.

**Additional clamps (not shown)**

- For an even better grip on thin, narrow or smooth materials
- For increased material throughput



**Pneumatically operated trim stops**

- The trim stops are attached to the clamps and are activated as needed by the CADmatic machine control.
- Rugged
  - Adjustable to common panel thicknesses
  - Gentle handling of sensitive materials with overhanging laminates or veneers
  - Precise positioning

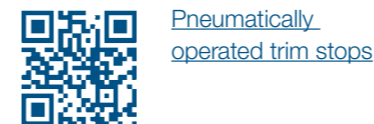

[Pneumatically operated trim stops](#)



**Clamp activation**

This option ensures panel edges are not damaged. Now also possible: Clamp activation in "Measuring" mode.



[Clamp activation](#)



**Cutting gap closers**

Open and close automatically during the machine cycle, preventing narrow strips or trimmings from getting caught in the cutting line.



**High-precision laser guide beam**

- Especially for solid wood, veneered panels and other materials with grain structure
- Pinpoint positioning right down the line



[Cutting gap closers](#)

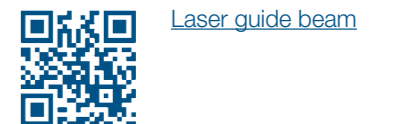

[Laser guide beam](#)

## Small measure, big effect

It is often the smallest details that make the difference. After all, when these details come together, they can have a noticeable impact on the speed and ease of the production process.



### Automatic outfeed fence

- Pushes panel remnants from the rear machine table across the cutting line to the front
- You no longer need to reach into the cutting area
- Ergonomic



### Dust-trap curtain on both sides

- Attached to the front and rear of the pressure beam. Dust-trap curtain only at the rear when combined with the label printer at the pressure beam (page 34)
- Protects operators from dust
- Improves extraction
- Ideal for dust cuts

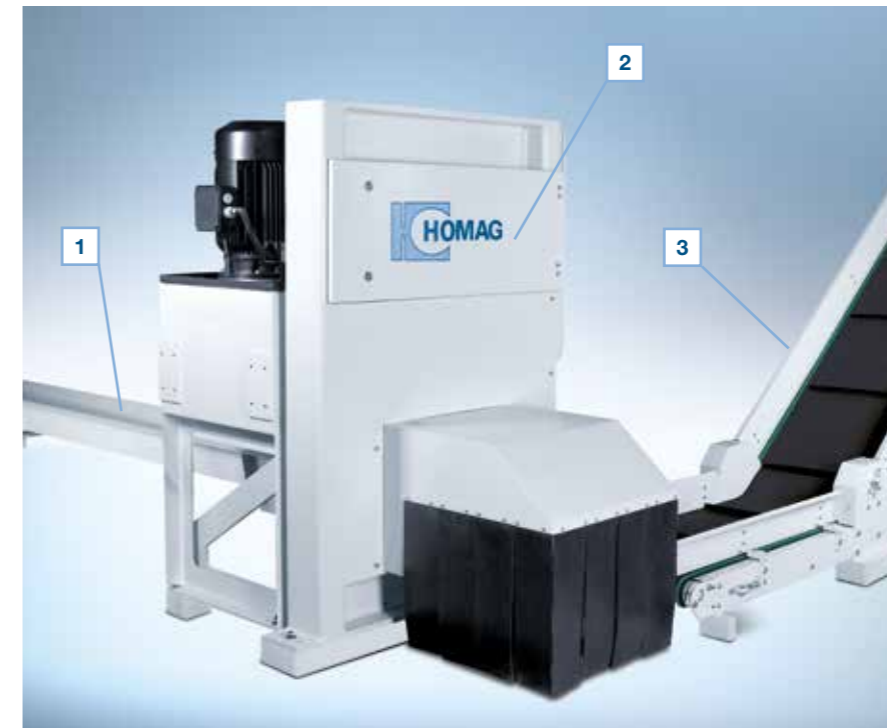

### Automatic waste removal (for HKL only)

- 1** Vibrating conveyor: Cutting waste that falls through the waste flap is collected here
- 2** Waste chopper: This cuts waste into small pieces, facilitating automatic removal of the cuttings
- 3** Elevating waste conveyor: Transports the waste to a container, for example



### Rotation device for headcuts

- Process integrated perfectly in the machine cycle
- Labor-saving device for operators
- With automatic aligning function
- Less time required for preparation
- Easy operation
- Significant increase in output

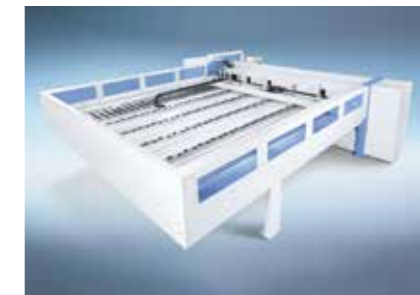

### Greater visibility while maintaining safety

The all-round protective guard on the rear machine table is equipped with a window as standard. All side elements can also be equipped with a window on request. This ensures greater visibility while maintaining safety levels.



### Additional start-stop button

- Allows the program sequence to be started independently of the operator control panel
- Equipped with an emergency stop button

### VIDEO:



[Rotation device](#)

## Power Concept speeds up production

At the heart of this technology is a clamp that can be moved separately. Using this clamp, several strips with different cross cuts can be cut to length together, significantly increasing material throughput.



### Power Concept PROFESSIONAL works with:

- An additional clamp which functions independently
- Clamps on the program fence that can be raised out of the work area if necessary
- Re-sorting the strips directly at the saw so that they are ideally matched to Power Concept PROFESSIONAL. This is based on existing optimization data for shortest machining times

### Simultaneous feeding and cutting without a separate infeed carriage:

The Power Concept PROFESSIONAL clamp positions the last strip at the cutting line while the program fence fetches the next panel or book of panels from the lifting table (HPL). Good to know: To ensure your machine operators can master the considerably faster pace of production with ease, we recommend combining systems with the HOMAG destacking concept (page 42) or with intelliGuide (page 44).

### Additional advantages:

- Significantly shortened cutting cycles
- Attractively priced high-tech solution with minimum space requirement
- Precision cutting of even very narrow strips

### VIDEO:



[Power Concept PROFESSIONAL](#)

Illustrations partially demonstrate the technical principle but are not an exact depiction of the machine version described. Optional features, for example, may be shown.



### Power Concept PRACTICE

This is the low-cost version of the successful Power Concept PROFESSIONAL — developed for the HPP 300 profiLine with feeding from the front and for saws with simple storage control connection without an integrated feed-stacking table. Power Concept PRACTICE can do everything that constitutes Power Concept, but can be integrated far more easily and consequently more economically.

## POWER CONCEPT

Up to **40%** more output



**Lower costs per cut**



**Significantly improved material flow**

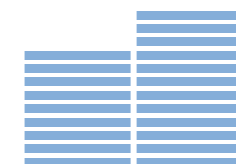

**High material throughput**



## Air cushions for ergonomic operation

How can your machine operators handle heavy or excessively long parts with ease, even those that are susceptible to scratches? With innovative, tailored machine tables and air cushion tables from HOMAG of course! The choice is yours.

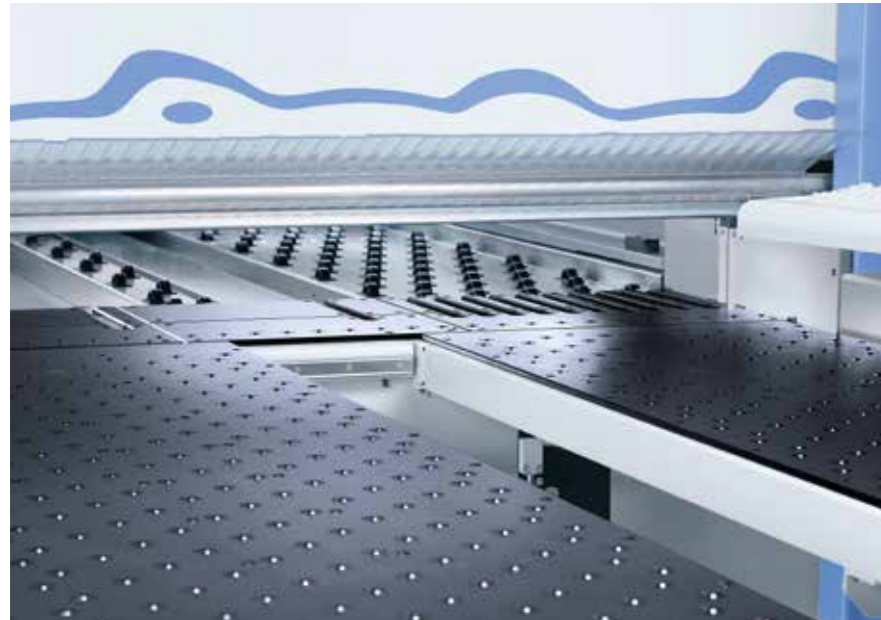

### Movable air cushion table

The movable air cushion table is easily moved along linear guides and offers you a mobile work surface and storage area. It allows you to move small panels, large panels or books of panels more ergonomically and with less risk of damage.

### Extended air cushion tables (not shown)

- Length increased from 2160 mm to 2810 mm
- Greater freedom of movement
- Better connection to destacking systems
- Very useful when cutting large-format panels

### VIDEO:



[Air cushion tables](#)

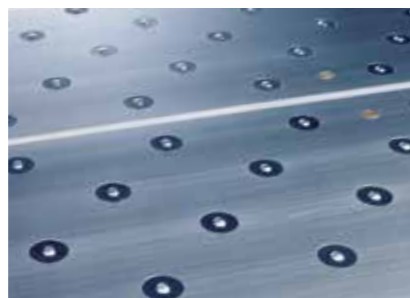

### Anodized aluminum machine bed plates

The special coating ensures exceptionally gentle material handling. Ideal for materials with highly sensitive surfaces.

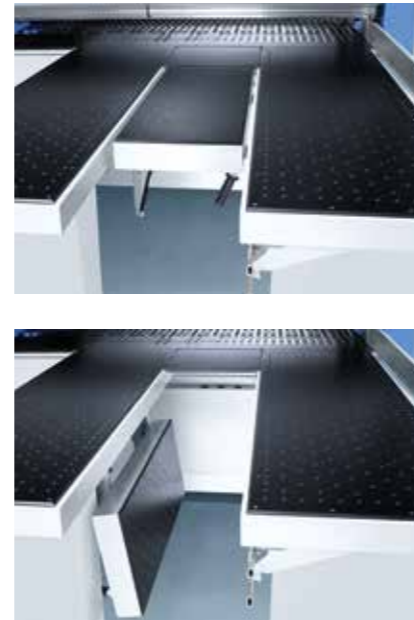

### Tilttable air cushion table

- Prevents thin materials from sagging
- Increases the work surface
- Primarily for large panels
- Folds down for easy access to the cutting line

## dustEx: Making dust a thing of the past!

The more dust and chips that can be taken away during extraction, the better. After all, dust and chips can cause scratches on sensitive surfaces.



### Patented dustEx technology

dustEx guides dust and chips on a direct route towards the extraction system. How does it work? Using combination air jets and an optimized extraction geometry at the right-angled fence. To complete the dustEx package, we recommend using a dust-trap curtain on either side of the pressure beam (page 28).

### Fully equipped with air jets: the machine table (included as standard with the HKL)

Anyone working with sensitive material or especially heavy panels and books will benefit from the machine table being equipped with air jets throughout.

### Light design (not shown)

- Consists of the following options:
- LED illumination of the cutting line
  - LED illumination of the saw blade change area
  - LED illumination in the switch cabinet
  - For simple, ergonomic working practices that protect the eyes

### VIDEO:



[dustEx](#)

## Custom part labeling

Whether generated automatically or manually on demand: With labelling solutions from HOMAG, you can clearly label each individual part and ensure parts can be identified at downstream processing stations.



### Label printer

The label printer from HOMAG allows you to print customized labels directly at the saw and design them to include bar codes, text and graphics if required. If you also use our Cut Rite optimization software, instructions for downstream CNC machining can also be included on the labels. In this way, you can integrate the saw perfectly in your production flow.



### Swing-arm label printer

The label printer can also be swiveled horizontally to ensure ergonomic working practices. Available in combination with the parts buffer (page 43).

### Fully automatic labeling

The labeler is located near the pressure beam, i.e. in your field of vision, and labels the finished parts/books even when several strips are processed simultaneously side by side (Power Concept). It makes no difference whether you feed the panels from the front or the rear. If desired, the position of the label can be individually controlled.

- Suitable for panels, offcuts and finished parts
- Gives precise details of the destacking location
- Gives precise instructions for further processing
- Saves time
- Minimizes errors
- Guides the operator

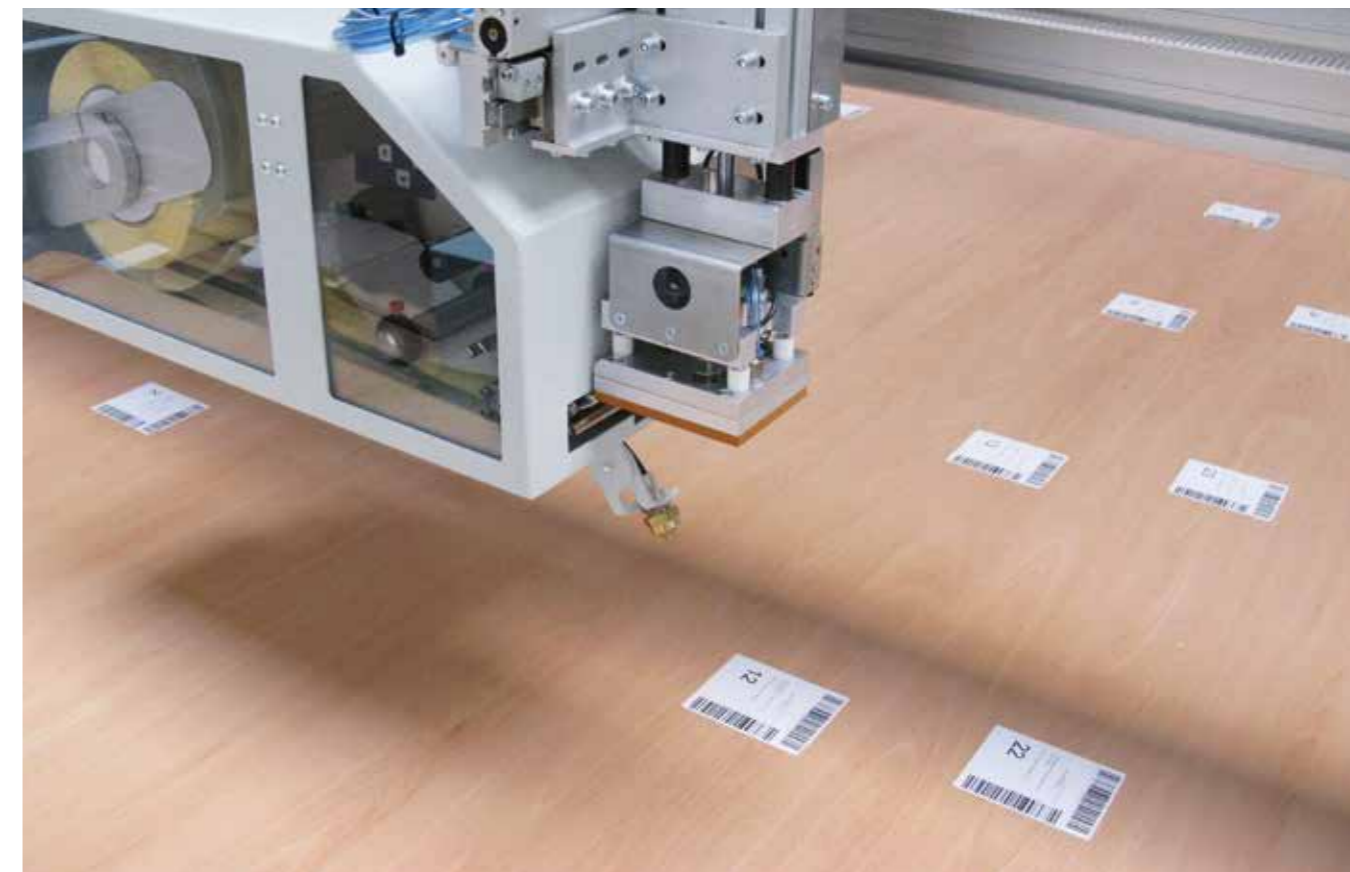

### Panel labeling system

The innovation for saws with automatic storage link-up: The HOMAG panel labeling system labels the unprocessed panel before it is cut — independently of the saw, in non-productive time that previously went unused. It can also be combined with the feed-stacking table with integrated feed (page 25).

- Smallest part size 170 x 170 mm
- Up to 10 labels/min, optionally up to 15 labels/min
- Labeling independent of cutting process
- Saves time, because non-productive time is used productively
- Optimizes handling during destacking, because all the parts are already labeled
- Simplifies and speeds up production processes
- Automated parts tracking
- Can be retrofitted
- For smooth processes

## VIDEO:



[Manual labeling](#)



[Fully automatic labeling](#)



[Panel labeling system](#)

## Solutions for special cutting tasks

Not only precise, but efficient. Under this banner, HOMAG offers you countless optional features for particular cutting tasks. Simply select **YOUR SOLUTION**.

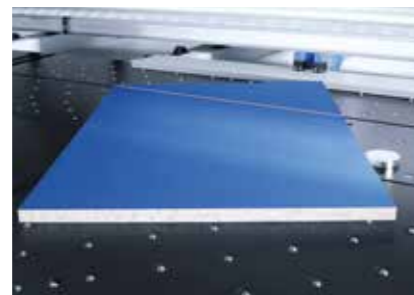
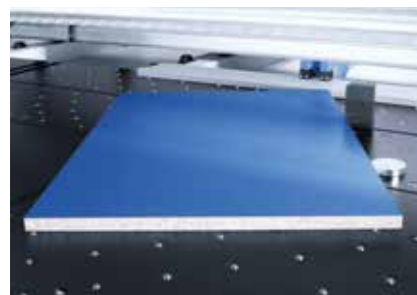
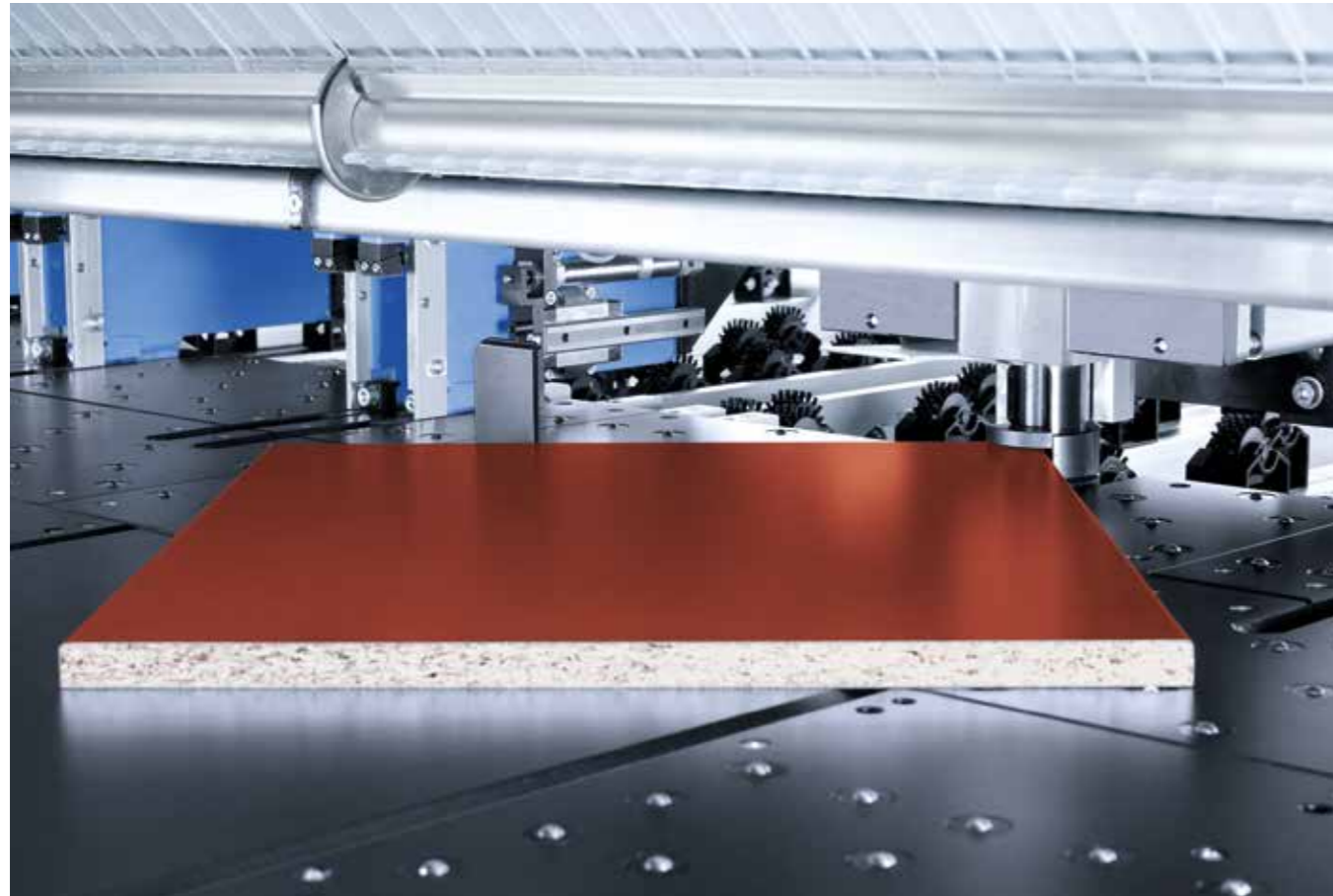

### Automatic angle cut device

This technology completes angle cuts fully automatically, after you have entered the respective data in the CADmatic control.

### Manual angle cut

The angle cut device allows you to control angle cuts using the CADmatic control software.

#### VIDEO:



[Manual angle cut](#)

Illustrations partially demonstrate the technical principle but are not an exact depiction of the machine version described. Optional features, for example, may be shown.



### Kerfing and turbo-grooving

These options save you an entire production step in subsequent processing. This is because your saw will also groove the panel material. The turbo-grooving option completes the grooves even faster than a processing center.

#### VIDEO:



[Kerfing](#)



### Cut-out and stress-elimination cut

Tension in the material is released when it is cut and can affect the quality of dimensions and cuts. The stress-elimination cut can provide a solution here. Systematic preliminary cuts can be defined during optimization and release the tension in the material. The additional cut-out feature also allows you to produce both cut-outs and intermittent grooves in panels, as are required, for example, for kitchen sinks or doors.



[Cut-out function](#)



[Stress-elimination cut](#)

## The perfect postforming cut

This option is available in two versions. Both include a scoring saw raised by a motor, complete with automatic adjustment.



### Version 1: Ascending postforming

- Ascending scoring saw
- Ensures perfect cuts on softformed and postformed parts
- Maximum saw blade projection: 55 mm

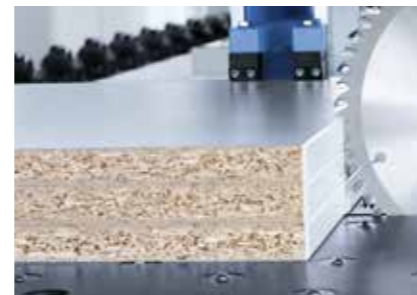
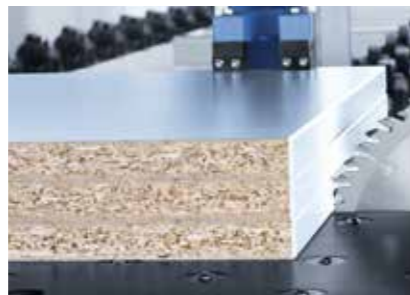

### Version 2: Ascending and vertical postforming

- Ascending scoring saw as described in Version 1
- Additional vertical scoring saw with a maximum saw blade projection of 90 mm
- Scores the edge of the entire book (scoring depth up to a maximum of 15 mm)
- Ideal for edges covered with veneer, paper, ABS etc.

### VIDEO:



[Postforming](#)

## combiTec performs recuts during the cutting process

Efficiency means saving time, material and costs — just like combiTec. The innovative recut function is ideal for all businesses that work in small production batches or even produce in batch size 1.

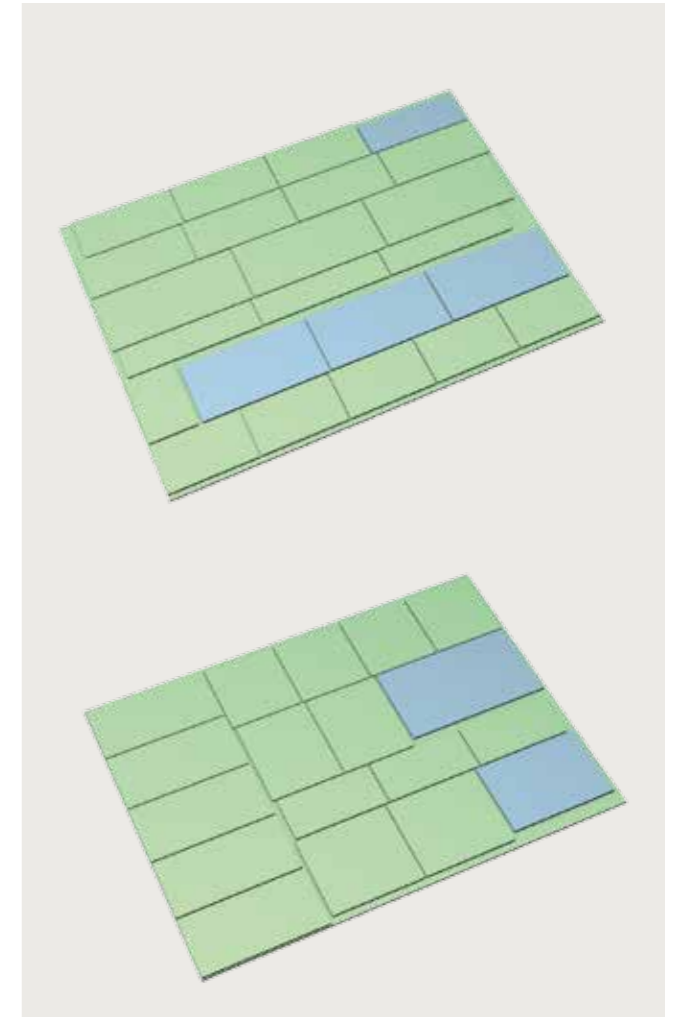

### combiTec speeds up batch size 1 production

The combiTec recut function is now available for all saws in the 3 series and optimizes batch size 1 production. This innovation completes all recuts fully automatically during the cutting process. Even complex cutting patterns can be generated and flexibly implemented. That saves time and material, thus reducing costs.

The benefits:

- Reduced material costs due to less waste
- No manual reworking
- High speed
- Low unit and tool costs
- Excellent price/performance ratio



[combiTec for angular saw units](#)



[combiTec for single saws](#)

## module45 — giving your saw the scope to produce bevel cuts

With this innovation from HOMAG, you can produce all cuts and bevel cuts using just one saw. Without changing station, efficiently and flexibly, at seamlessly adjustable angles ranging from 0 to 46 degrees.

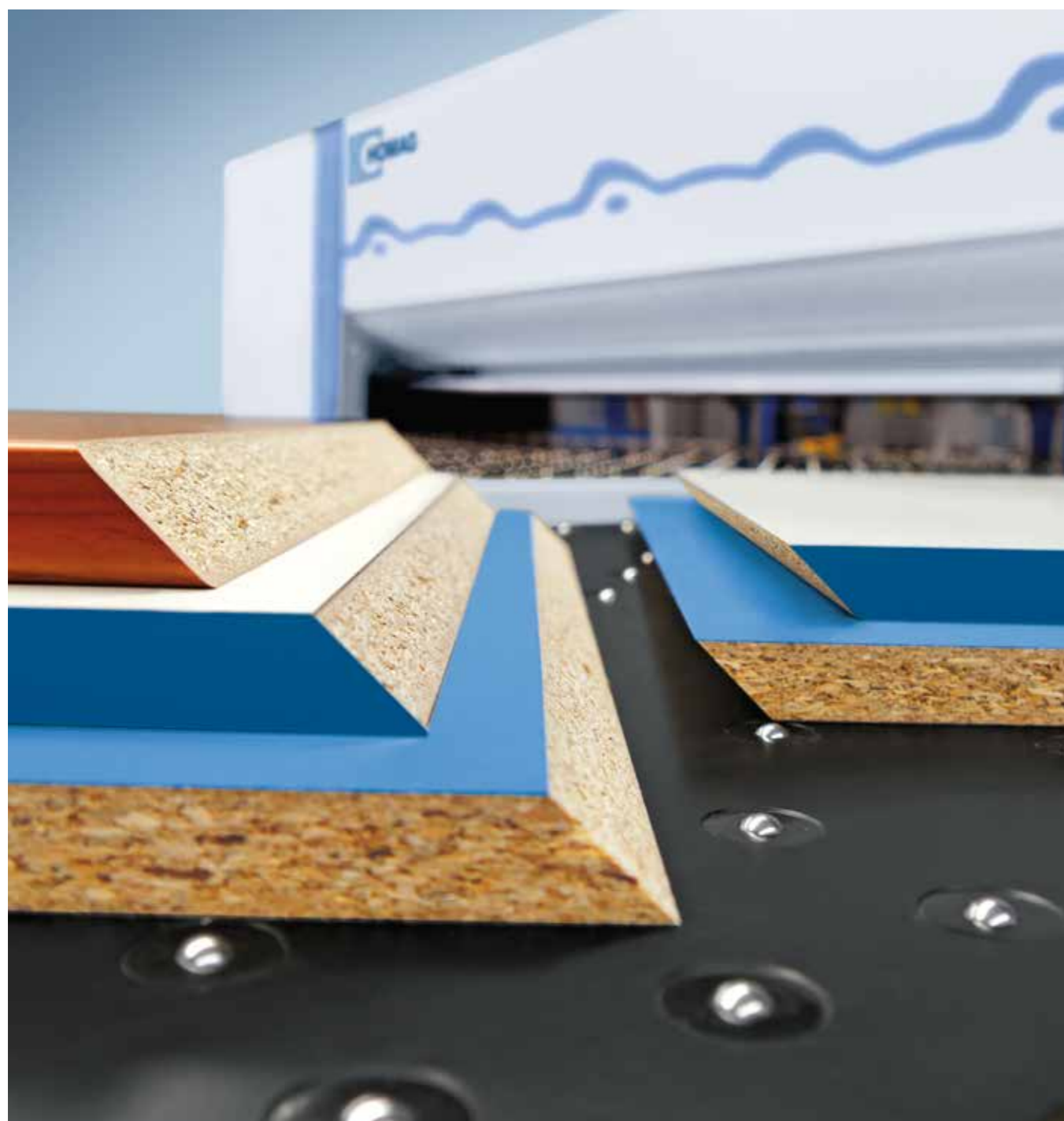

Illustrations partially demonstrate the technical principle but are not an exact depiction of the machine version described. Optional features, for example, may be shown.



### The technology

- module45 consists of a stationary saw carriage with a swiveling saw blade that can be seamlessly adjusted to angles of 0 to 46 degrees
- When viewed from the front, the unit is integrated in the air cushion table on the far left
- The table plate can be opened, allowing easy access to the saw carriage for changing saw blades
- Other features include dedicated systems for contact pressure and dust extraction, plus a fold-down right-angled fence for maximum handling flexibility at the front of the saw

### Incorporate bevels into cutting patterns

Now you can also incorporate bevel cuts into your cutting patterns: either using the Cut Rite optimization software when preparing work in the office, or when inputting the patterns directly in CADmatic. With module45, parts for processing are then adjusted such that all the operator needs to do is enter the angle of the bevel and start the cut.



### The benefits of module45

- Low investment costs, great benefits
- You no longer need a sliding table saw for bevel cuts
- Higher energy efficiency as two machines in one
- Easy one-man operation
- Less waste and higher quality thanks to less transport damage as the material remains on the one machine
- Greater ergonomic benefits and higher reliability than a circular saw
- Unbeatable value for money
- Retrofit on request

### VIDEO:



[module45](#)

## Operator guidance: quick and error-free with the destacking concept

This concept, which comprises software and hardware, guides the operator from depositing the first part to forming the perfectly stacked pallet. An LED display indicates, at the same time as the monitor, when a cut part is to be pushed onto, or removed from, the parts buffer. The system uses the parts buffer so intelligently that stack formation is greatly improved. Even waste parts are put to good use.

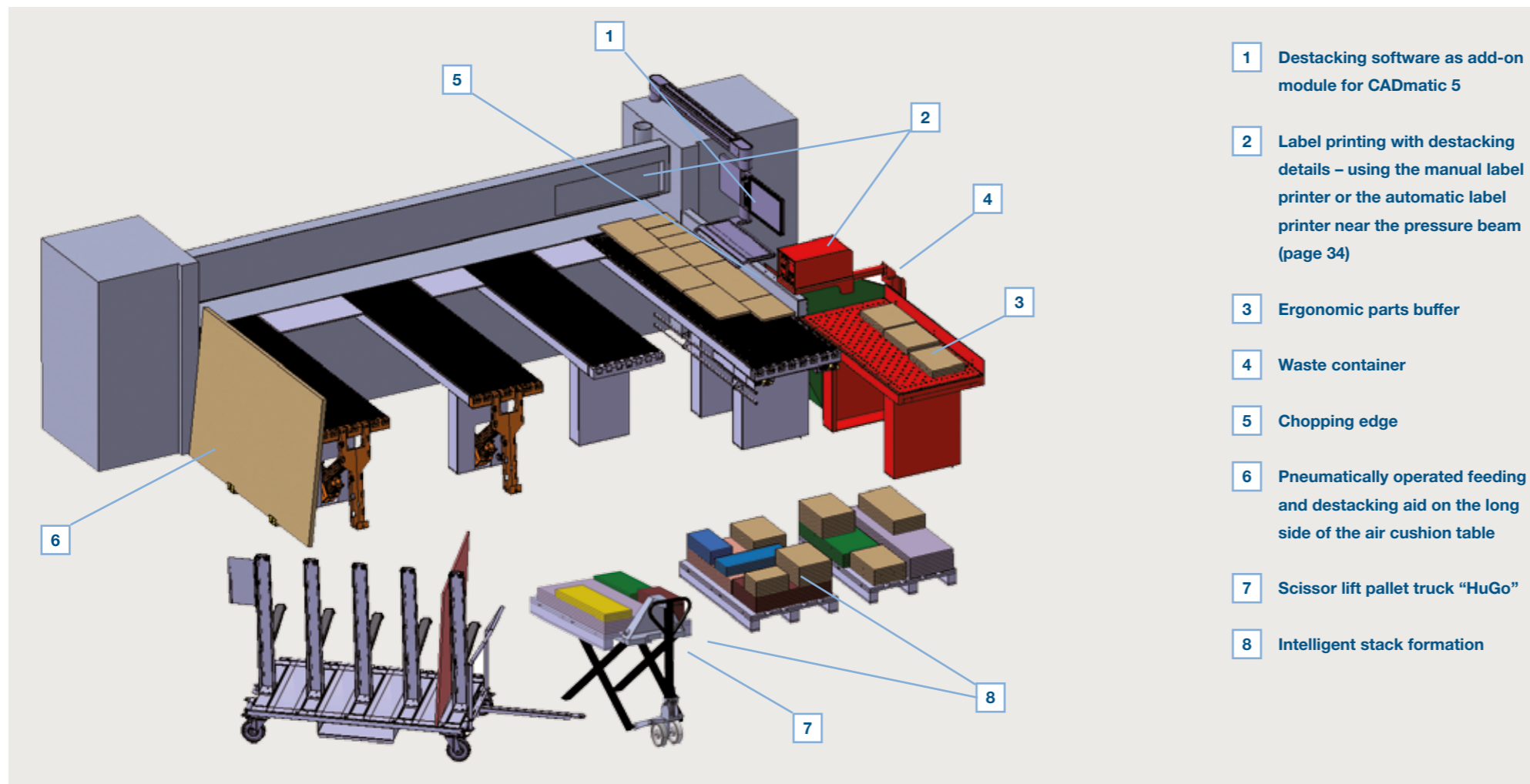

- 1 Destacking software as add-on module for CADmatic 5
- 2 Label printing with destacking details – using the manual label printer or the automatic label printer near the pressure beam (page 34)
- 3 Ergonomic parts buffer
- 4 Waste container
- 5 Chopping edge
- 6 Pneumatically operated feeding and destacking aid on the long side of the air cushion table
- 7 Scissor lift pallet truck “HuGo”
- 8 Intelligent stack formation



### Parts buffer with swiveling label printer

The parts buffer with swiveling label printer increases the efficiency of processes and optimizes handling. It provides an ergonomic buffering area for parts after cutting. The integrated printer allows the operator to work in a comfortable position and dispenses the right label for each part at the right time.

### Scissor lift pallet truck “HuGo”

The scissor lift pallet truck, fondly referred to as “HuGo”, is equipped with automatic height control and facilitates ergonomic and smart destacking processes. A light barrier controls the automatic raising and lowering of the pallet truck, allowing you also to remove all the parts from the pallet at an ideal working height, for example, at an edge banding machine.

The operator always knows when and where to stack each specific part. Times and routes that do not add value are systematically reduced. The interaction of hardware and software components increases the efficiency and ergonomics of the destacking process.

### Additional advantages:

- The parts buffer is integrated into the process in an anticipatory way
- Errors are virtually eliminated
- Stack formation is bound to the destacking strategy
- This produces stable stacks in a logical order, requiring significantly less space

### VIDEO:



[Destacking concept](#)



[„HuGo“](#)

# Operator guidance: A smart, innovative approach with IntelliGuide

IntelliGuide is the first assistance system in the history of panel dividing technology to allow saws to respond flexibly and intelligently to the actions of the machine operator. The assistance system becomes more intelligent with each stage of expansion: from IntelliGuide basic, to advanced, right through to professional. So you get exactly **YOUR SOLUTION**.



### The foundation:

#### 1. CADmatic 5

IntelliGuide is the result of a long period of technical evolution. It all started with the CADmatic saw control system: a piece of software that has since become indispensable in the industry. The new version of the software, CADmatic 5, is now more focused on the user than ever before. This is thanks to a new assistance graphic in CADmatic 5 that clearly shows operators the next step they have to perform. Compared to the previous process graphic that showed all work steps on the saw directly (and can still be called up if required), this is a 180-degree change in perspective!

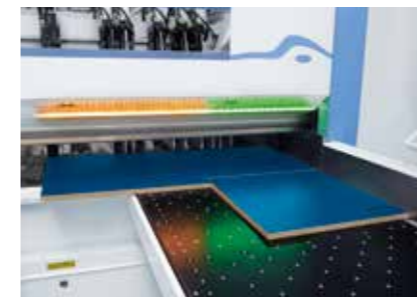

### IntelliGuide basic:

#### 1. CADmatic 5

#### 2. LED strip on the cutting line

- Colored LED signals on the cutting line allow intuitive operation and a speedy and safe way of working
- Using the colored LED elements, machine operators can immediately see if a part has been fully processed, needs to be cut again or can be disposed of as a waste part
- Based on the LEDs that are lit up, the operator can determine whether the part that has been deposited meets requirements



### IntelliGuide advanced:

#### 1. CADmatic 5

#### 2. LED strip on the cutting line

#### 3. Camera

- The system uses this camera to see which strip or part the operator has deposited and how it has been aligned
- If the intended part is not deposited, IntelliGuide responds to the change of plan in a flexible manner
- If the change does not call for any additional action, the saw simply begins working. Otherwise, IntelliGuide provides the operator with feedback and instructions

#### 4. Illumination

- Enhances safety and quality by ensuring that workplace and workpieces are evenly lit
- Improves the appearance of the workplace and makes it even more ergonomic

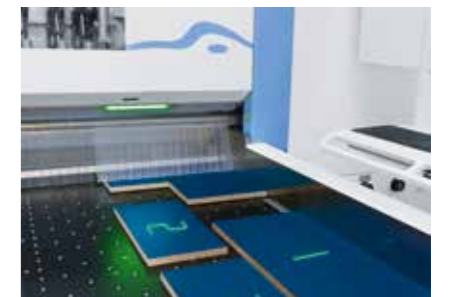

### IntelliGuide professional:

#### 1. CADmatic 5

#### 2. LED strip on the cutting line

#### 3. Camera

#### 4. Illumination

#### 5. Laser

- Projects clear information regarding processing and handling directly onto the current workpiece
- Arrows, for example, indicate the direction in which a panel needs to be turned and how it needs to be positioned. An X means that the wrong part has been inserted. The trash can symbol indicates waste parts
- In short: Thanks to the self-explanatory symbols and icons, operators know what step they need to perform next and can immediately take the appropriate action

### General benefits of IntelliGuide

- Completely intuitive machine operation
- Systematic means of avoiding errors
- Fast processes: Operator and saw work hand in hand and no longer work against one another
- The operator can work through the cutting pattern without looking at the monitor once
- Fluid, ergonomic processes for efficient and concentrated work
- Smooth change of operator possible at any time

### VIDEO:



[IntelliGuide](#)

# More software, greater efficiency and control

Do you want to produce even more efficiently and monitor production processes with greater ease? You will find the right technology and software solutions for your cutting application here.



### Cut Rite cutting optimization software

Efficiency through planning: The key benefits of the Cut Rite software can be summed up in this short phrase. With this leading software solution, you can optimize waste and systematically lower overall costs for cutting.

- Optimized project control
- Efficient cutting processes
- Full control of costs
- Faster calculations

Find out more in the HOMAG “Cut Rite” brochure.

### Add-on module CADplan

As an alternative to the comprehensive Cut Rite optimization software, CADplan, an add-on module for CADmatic, can also be used to perform small optimization jobs directly at the saw.

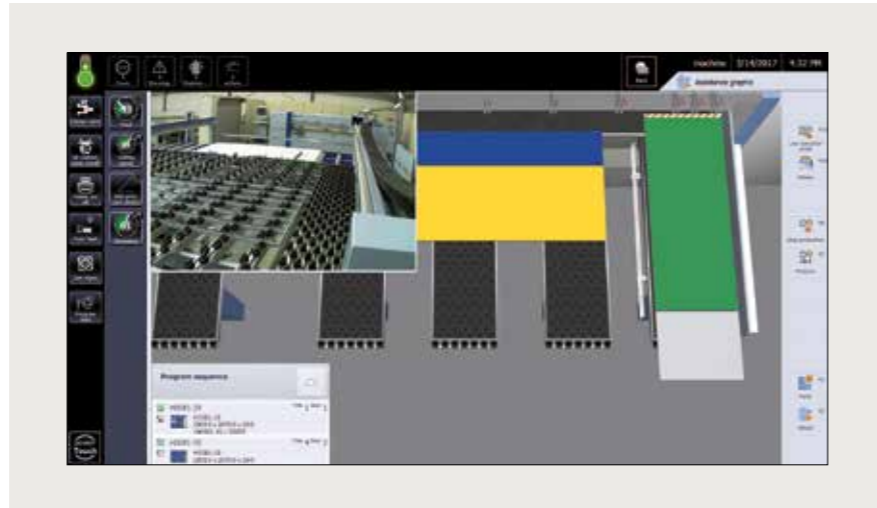

### Everything in view – with video monitoring

- Display of the camera image via CADmatic control software
- You always have the rear machine table and feed system in view
- Camera pictures can be recorded on request for error diagnostics and workflow optimization purposes and sent to the HOMAG Service department



### Patented: camera-controlled scoring saw adjustment

This option allows the scoring saw to be adjusted fully automatically. Manual adjustment is still possible – controlled by the software via input on the touchscreen.

Its strengths:

- Optimum measuring results: The camera selects the color of lighting and the exposure time itself
- The simple adjustment takes no longer than a minute
- High-precision adjustment

TECHNICAL DATA*			
Model	HPP 300	HPL 300	HKL 300
Saw blade projection (mm)	80 (95 as option)	80 (95 as option)	80 (95 as option)
Cutting length/width (mm)	3200/3800/4300/5600*****	3200/3800/4300/5600*****	rip saw: 3200/4300/5600 cross cut saw: 2200 (2100*****)
Lift table width (mm)		2200	2200
Program fence speed (m/min)	up to 90 **	up to 90 **	rip saw: up to 90 ** cross cut saw: up to 130 **
Saw carriage speed (m/min)	up to 130 (optional: 150)	up to 130 (optional: 150)	up to 130 (optional: 150)
Main saw motor (kW)	50 Hz: 11 (optional: 18 or 24) 60 Hz: 11 (optional: 21 or 28)	50 Hz: 11 (optional: 18 or 24) 60 Hz: 11 (optional: 21 or 28)	50 Hz: 11 (optional: 18 or 24) 60 Hz: 11 (optional: 21 or 28)
Scoring saw motor (kW)	1.5 (2.2 as option)	1.5 (2.2 as option)	1.5 (2.2 as option)
Average total air demand (NI/min)	140	200	450
Required compressed air supply (bar)	6	6	6
Dust extraction (m <sup>3</sup> /h)	3800 (5230****), 26 m/sec	3800 (5230****), 26 m/sec	6600 (9030****), 26 m/sec
Max. stack height without pit (mm)	–	560 (up to 4300 cutting length) 450 (up to 5600 cutting length)	560 (up to 4300 cutting length) 450 (up to 5600 cutting length)
Max. stack weight (t)	–	4 (5600 mm cutting length: 7)	4 (5600 mm cutting length: 7)
Working height (mm)	920	920	920
Air cushion tables (mm)	3/3/4/5 x 2160	3/3/4/5 x 2160	2 x 2160

\* Values refer to the standard version

\*\* Forwards 25 m/min

\*\*\* Dim. A: incl. 64 mm for extraction connection, Dim. C: Standard program fence width; there are wider dimensions for the lift table with HPL and HKL machines

\*\*\*\* For the 5600 mm cutting length

\*\*\*\*\* Only right-handed version

\*\*\*\*\* Maximum width that can be aligned

Technical data and photos are not binding in all details. We reserve the right to make changes in the course of further development.

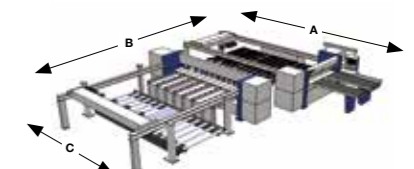
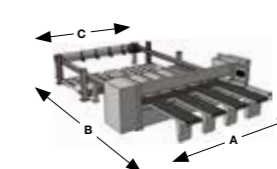
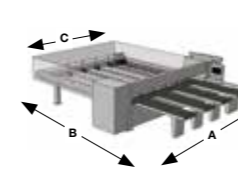

MACHINE DIMENSIONS***			
HPP 300	A (mm)	B (mm)	C (mm)
HPP 300/32/32	5364	6543	3709
HPP 300/38/32	5924	6543	4269
HPP 300/38/38	5924	7143	4269
HPP 300/43/32	6514	6543	4859
HPP 300/43/43	6514	7693	4859
HPP 300/56/56	7864	9043	6209

MACHINE DIMENSIONS***			
HPL 300	A (mm)	B (mm)	C (mm)
HPL 300/32/22	5364	9693	3636
HPL 300/38/22	5924	9693	4196
HPL 300/43/22	6514	9693	4786
HPL 300/56/22	7864	11413	6136

MACHINE DIMENSIONS***			
HKL 300	A (mm)	B (mm)	C (mm)
HKL 300/32/22	8020	11760	3636
HKL 300/43/22	9170	11760	4786
HKL 300/56/22	10520	11760	6136



**HOMAG Plattenaufteiltechnik GmbH**

Holzmastrasse 3  
75365 Calw-Holzbronn  
Germany  
Tel. +49 7053 69-0  
info-holzbronn@homag.com  
www.homag.com



For the success of original technology.  
A VDMA Campaign