

accord wd

Cnc Machining cell for doors and windows

accord wd

Cnc Machining cell for doors and windows

Flexible work cell for the production of door and window frames, fitted with automatic loading and unloading.

It can be used for productions in batches and in single units without ever interrupting the work cycle and always feeding at the maximum speed.

Easy and fast to use also with manual loading to produce any type of element and therefore exploit all the potential of an SCM work centre.

- **COMPLETELY AUTOMATIC**

The automatic workpieces movement system and the worktable NC management ensure that the continuous presence of the operator is not necessary.

- **REDUCTION OF DOWN TIMES**

The pendulum machining, with workpieces loading and unloading in masked time and tool replacement in just 5 seconds, with the "Mach 5" tool changer, reduce down times to a minimum.

- **EASY PROFILING**

The 5-axes machining unit, designed and constructed specifically for demanding jobs, is supported by a rigid mobile gantry-type structure for fast profiling of large section elements.

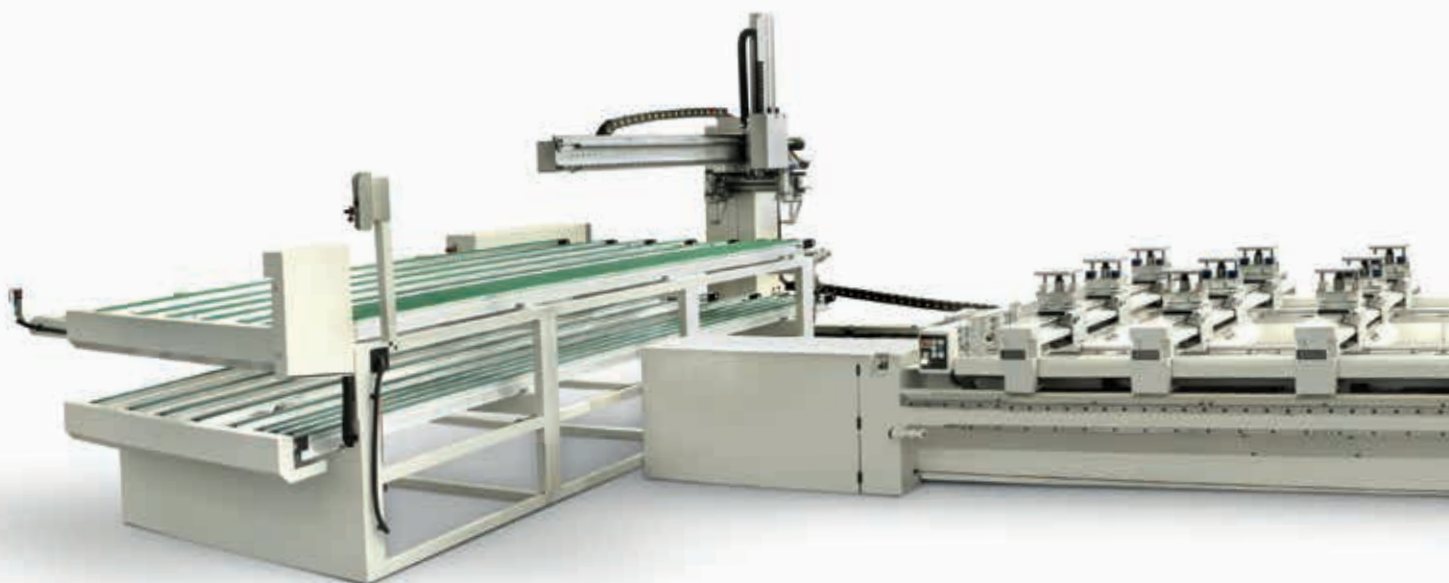



accord wd

technological advantages

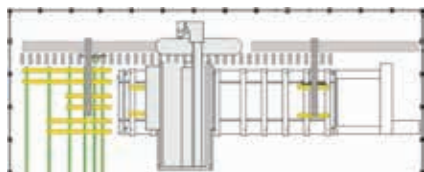

A NEW PRODUCTION STANDARD

The work cycle is never interrupted: while the machine is machining on one half-table the finished workpieces are unloaded from the other one and new ones loaded.

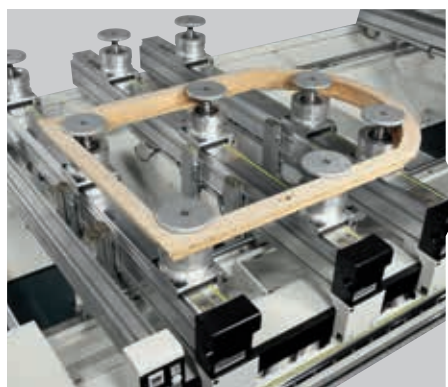

LIMITLESS USE FOR MAXIMUM FLEXIBILITY

Machining special door and window frames or other types of products is extremely simple as the worktable can be accessed also for manual loading and unloading.



SPEED AND PRECISION

The 5-axes machining unit, designed and constructed specifically for demanding jobs, ensures profiling of large section elements with fast feed speeds.



accord wd

**machining head:
main routing unit**



The electrospindles of SCM, with HSK 63 E tool holder, are powerful and reliable. They allow the use of tools of large dimensions and with double profile ensuring ease of profiling on elements of large cross-section.



The H145 worktable allows maximum freedom of movement with tools and even use of “double-profile” tools.

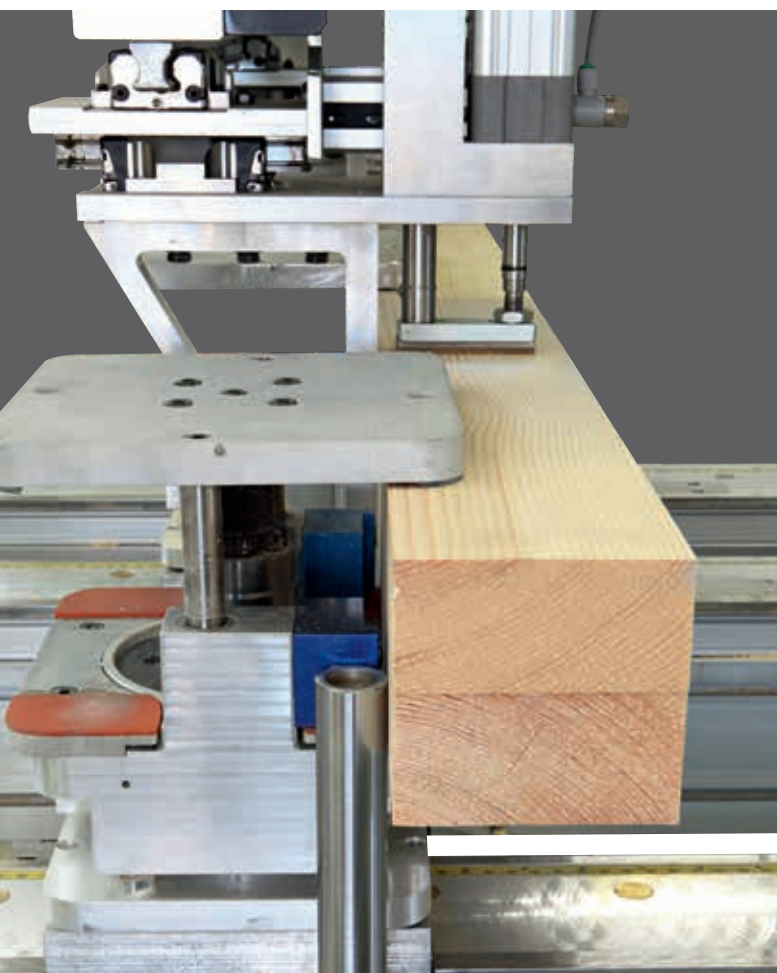

The square shaped hold down clamps are designed to efficiently block linear workpieces of any section; they are indispensable to hold down short workpieces.

Clean working environment with the exclusive chip conveying device, that is located directly on the electro-spindle and doesn't require additional tool-change to be activated/de-activated. It helps to eliminate shavings and saw-dust. Available for heads with 3 or 5 axes, it can be used both with single-profile tools and double-profile tools.



**machining head:
BRC multi-function unit**

Cutting, routing and boring both vertically and horizontally, without needing the tool changer, using the **BRC unit**. Fast and precise for all accessory machining, for making a door or window frame there is a single secondary unit using an independent Z axis and dedicated inverter.



accord wd

tool magazines



“Mach 5” in only 5 seconds replaces the tool drastically reducing down-times.

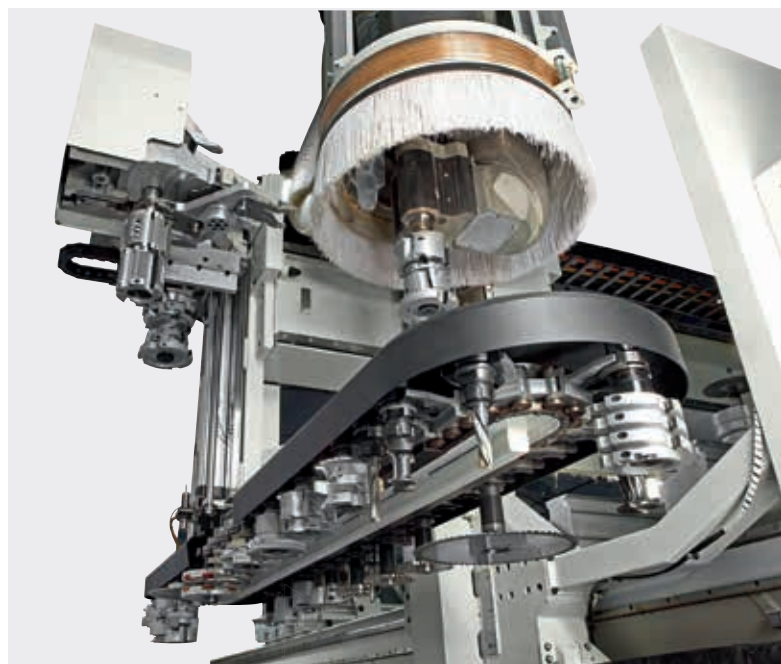

The machine is always equipped for any machining using the TRC chain magazine with 48 locations available for large and double-profile tools.

“matic” automatic worktable

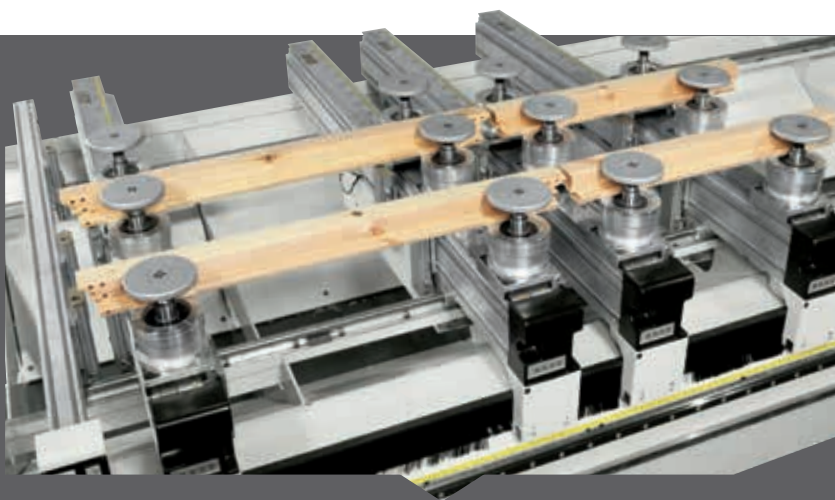

Matic is the fully automatic worktable ideal for machining solid wood. Complete set-up in seconds, all bars and supports moving simultaneously, each driven by an independent motor. The many technical devices give this table lasting safety and reliability.



Perfect for machining pre-finished/ finished door and window frames, all supports having cleaning blowers which remove all shavings from the sliding zone and on the workpiece hold-down base during clamp changes.

work cycle

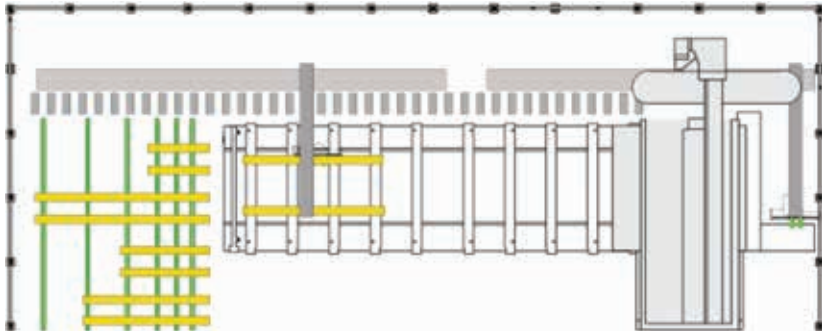

The left handling unit picks up the unfinished workpieces from the loading buffer (upper table) and deposits them on the left half-table.

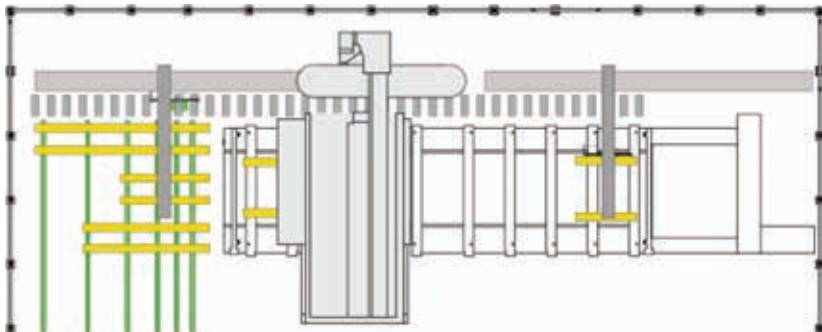

While the machine executes the program on the left half-table, the right handling unit receives the next unfinished elements from the rear roller conveyor and deposits them on the right half-table.

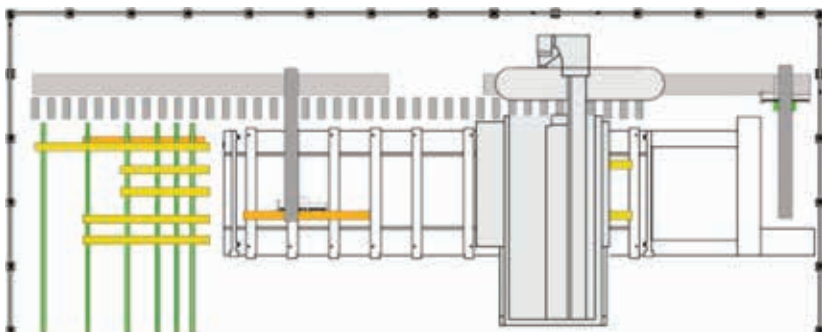

Once the program is finished, the left handling unit unloads all the finished elements from the left half-table and deposits them on the unloading buffer (lower table).

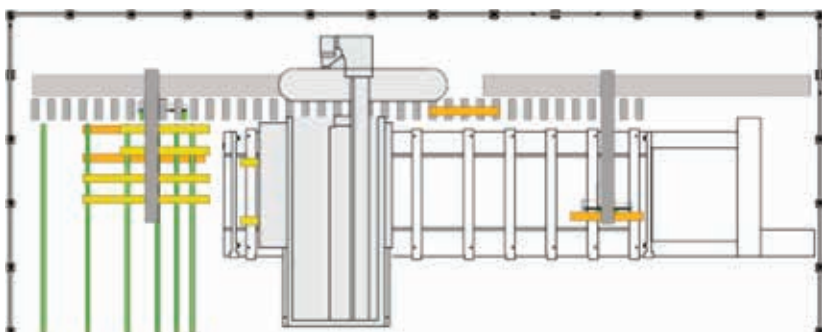

The cycle is completed by unloading the elements from the right half-table, while the machine is already machining the next elements on the left half-table.

accord wd

automatic loading and unloading system

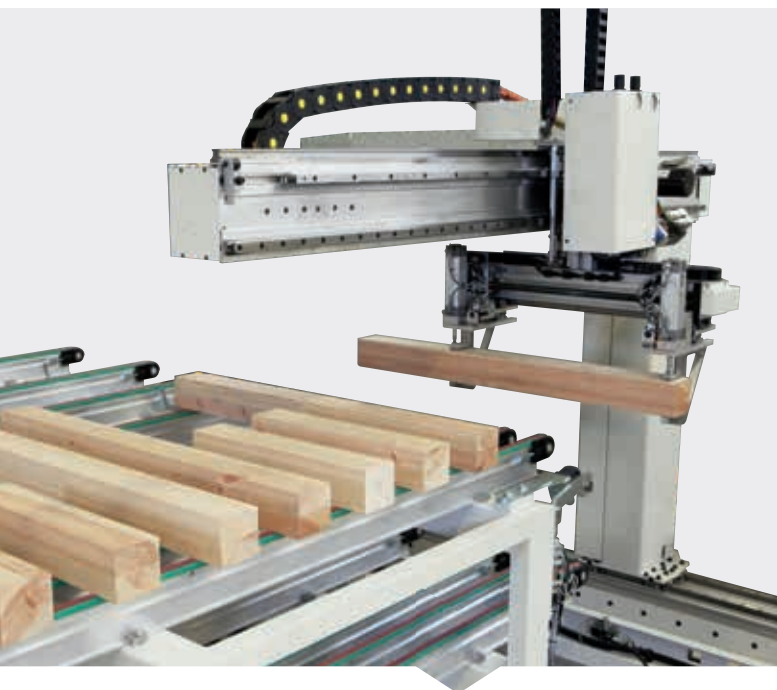

Several elements, of different length, can be positioned on the loading buffer. When the operator loads the element, its dimensions (length, width, thickness) are checked with an optical sensor.

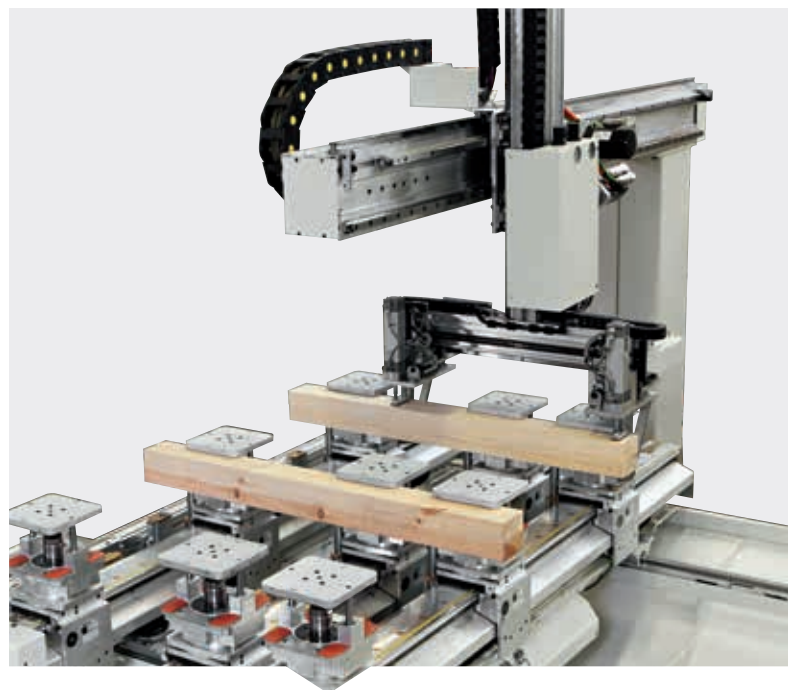

For increased productivity two elements can be always be machined at the same time on the work half-table.

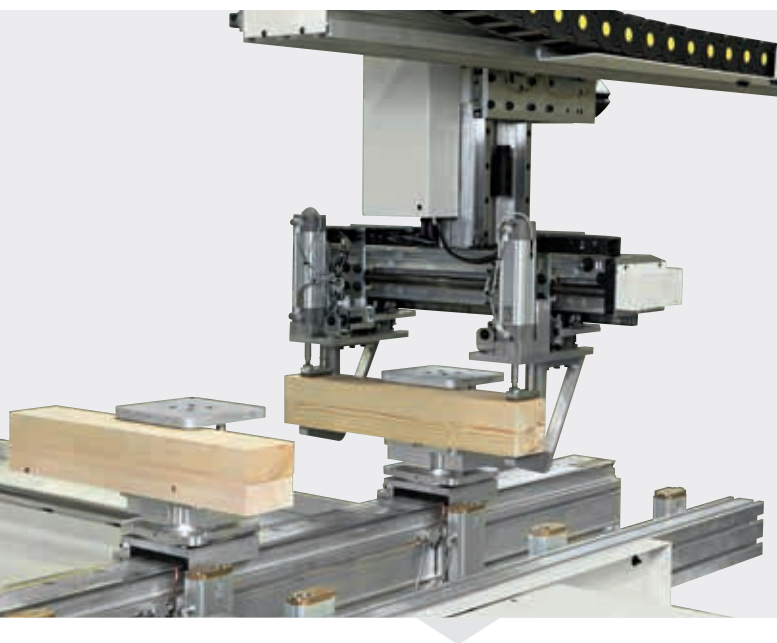

Short elements are loaded automatically and blocked with a single clamp.

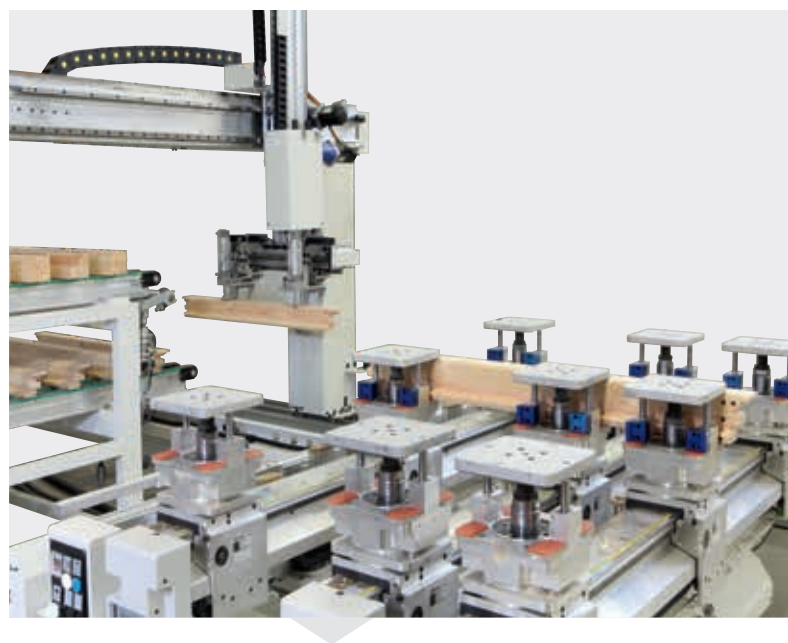

The handling units are positioned with NC controlled axes. The clamping devices are positioned automatically, according to the length and width of the work-pieces.

xilog maestro software

Xilog Maestro is the new powerful **CAD-CAM programming software** dedicated to SCM Group machining centres. Developed in the Windows® environment, it includes all the features and performance that allow easy, intuitive and effective programming.

- 3D graphics editor for workpiece, geometries, machining and worktables
- CAD mode geometries drawing functions
- Programming machining operations on angled faces
- Import DXF files
- Macro writing via editor or scripting
- Production times calculation
- Teleservice

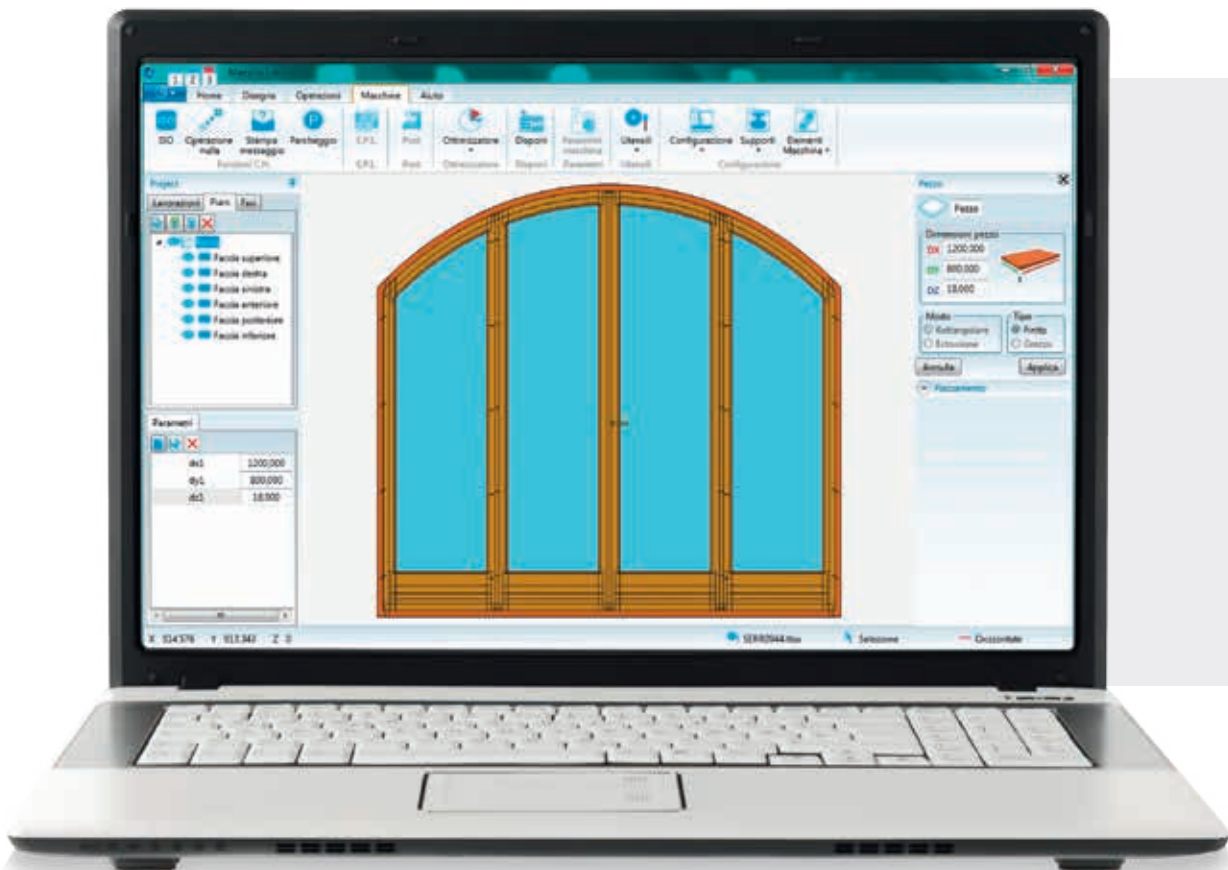

accord wd

maestro wd software

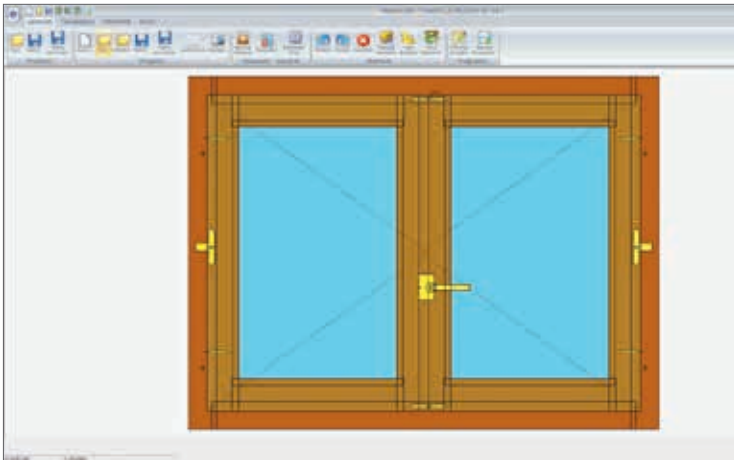

Parametric software developed by SCM Group to design and produce door and window frames on work centres. Supports the design requirements of the most common types and geometric shapes of door and window frames, both linear and curved.

A simple and intuitive graphic interface guides the user through every step of the project all the way to creating the machine programs.

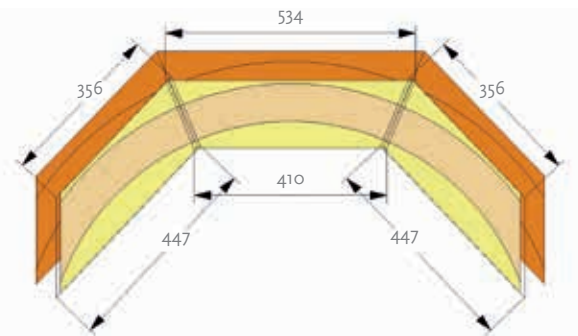

preview software

Simulation software developed by SCM Group for work centres.

Provides the operator with a three-dimensional virtual representation of the machine in his office. The operator interface and the programming software are the same ones installed on the machine.

- Real representation of the workpiece being machined and the machine parts
- Generation of reports, with collision checks
- Real representation of the material removed during machining
- Generation of reports with program execution times

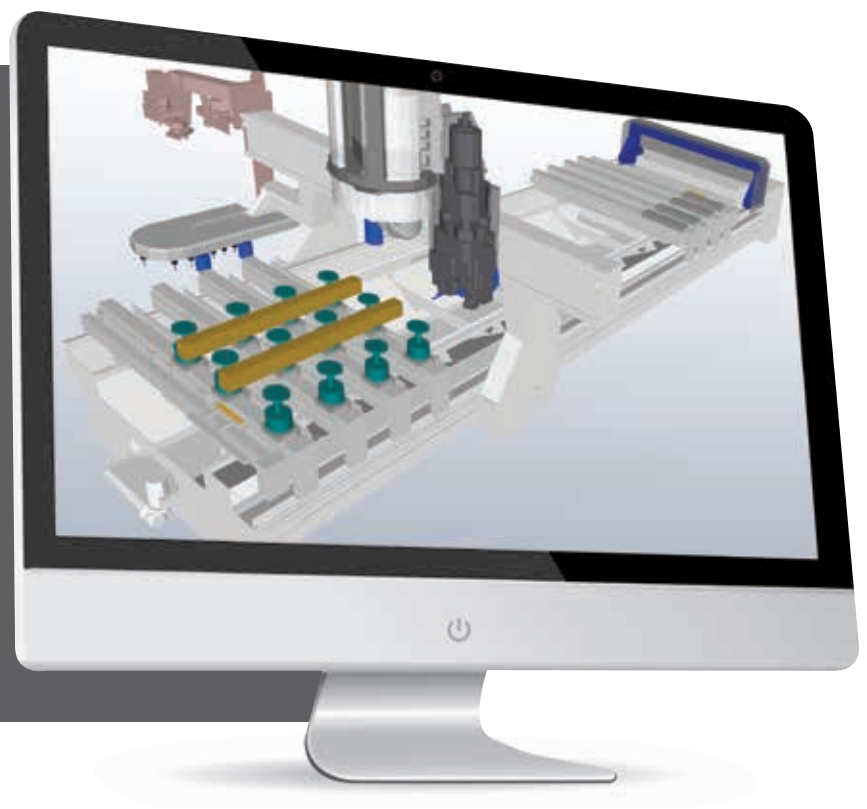

MSL software



Sav€nergy, high performance and energy saving.



Sav€nergy

- Optimum feed speed depending on the material and tool
- Recovery of energy produced during electrospindle braking
- Optimisation of compressed air consumption
- Optimisation of vacuum pump speed of rotation, depending on the vacuum required
- Electrospindle heat exchanger management, depending on the operating temperature
- Automatic switch to stand-by for motors not being used for machining, manual or NC
- Opening of the exhaust outlets related to the machining in progress.

The technical data can vary according to the requested machine composition. In this catalogue, machines are shown with options. The company reserves the right to modify technical specifications without prior notice; the modifications do not influence the safety foreseen by the CE Norms.



accord wd

technical features

ACCORD WD

Overall dimensions

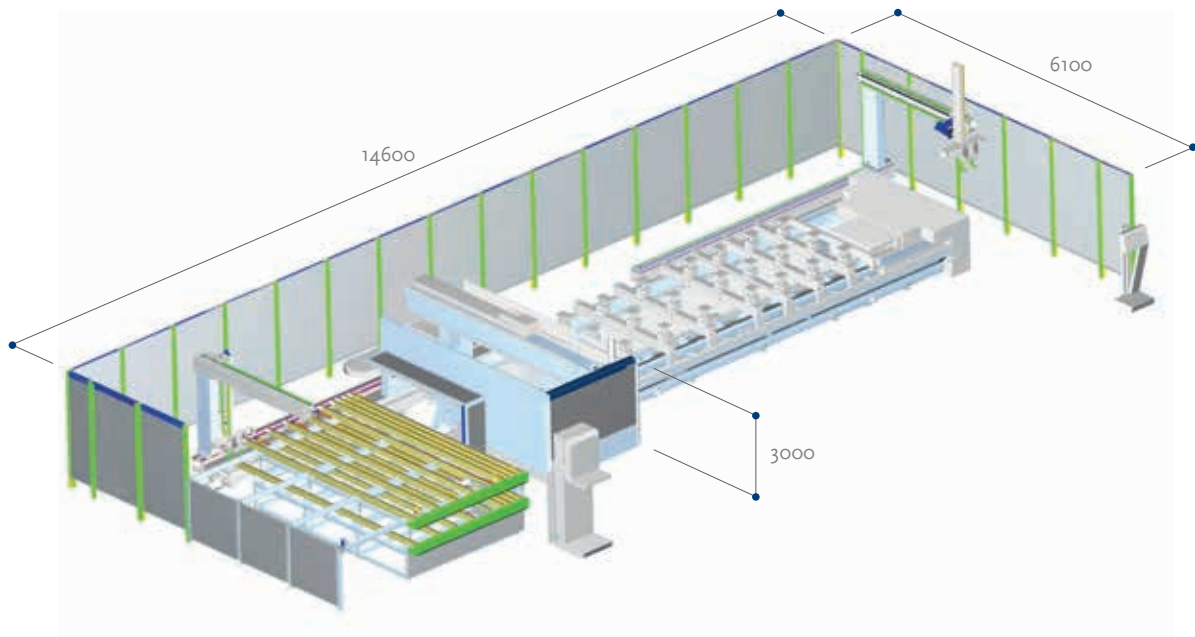

ACCORD WD

Technical data

CNC Machining Cell		ACCORD WD
Axes		
X-Y axes speed	m/min	90
Electro-spindle and Tool changer		
5-axis electro-spindle power	kW	13
Max. rotation	RpM	18000
Rear tool magazine	nr. pos.	48
Mach 5 – Shuttle for rapid tool change	T.tc	5 sec.
BRC		
Power	kW	3
Max. rotation	RpM	18000
Saw blade unit	mm	D = 300
Horizontal boring unit	nr. spindles	2
Horizontal routing unit	nr. tools	2
Installation		
Suction opening diameter	mm	1 x 100 - 1 x 250
Suction air speed	m/sec	25
Suction air consumption	m ³ /hr	1 x 1300 - 1 x 4400
Compressed air consumption	NL/min	170 - 300
Machine weight	Kg	6000 - 9000

scm
 minimax
 scm tecmatic

scm
 routech
 celaschi
 dmc
 superfici
 sergiani
 gabbiani
 morbidelli
 mahros
 stefani
 cpc
 sag
 scmgroup
 delmac
 scmfonderie
 steelmec
 hiteco
 es
 csr

CMS Cms
 wood technology

CMS Cms
 advanced materials technology

CMS Brembana
 stone technology

CMS Brembana
 glass technology

CMS CmsPlast
 plastic technology

CMS Tecnocut
 waterjet technology

CMS Balestrini

1 large integrated group
 18 production sites
 27 specialist brands
 20 foreign branches
 more than 50 years in business
 80% exports
 350 agents and distributors
 390 registered patents
 500 engineers
 3.000 square metres showroom
 10.000 classical and professional
 machines made per year
 240.000 square metres
 of production space



www.scmgroup.com



SCM GROUP SPA SCM - Via Casale, 450 - 47826 Villa Verucchio, Rimini - Italy
tel. +39 0541 674111 - fax. +39 0541 674235 - housing@scmgroup.com - www.scmgroup.com



00L0184079A